

Solenoid Directional Valve

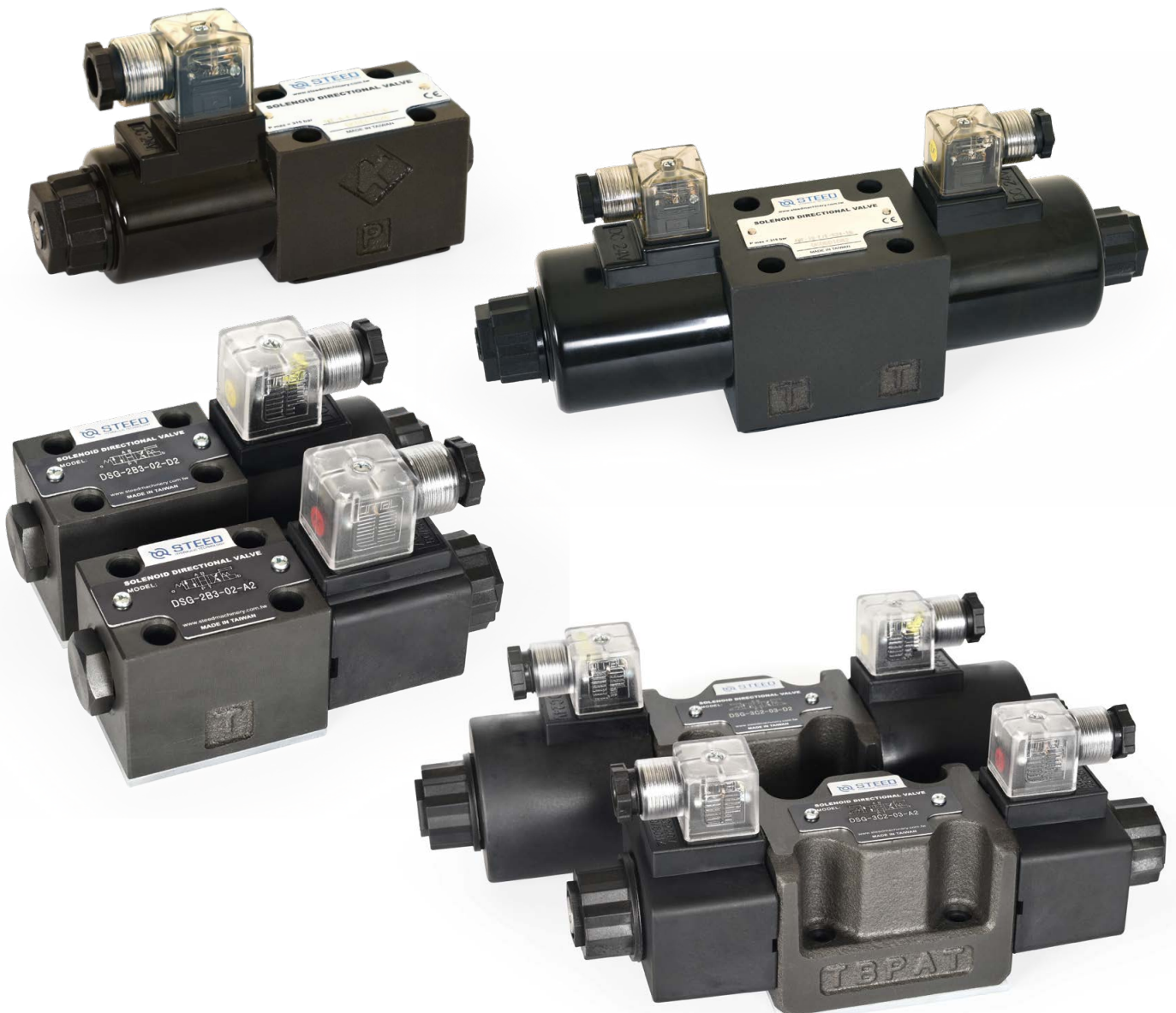

Solenoid Directional Valve

Index	5
4WE-06	6
4WE-10	12
DSG-02	18
DSG-03	22
DSG-02-AC24	26

Pilot Operated Directional Valve

DHG	29
-----------	----

Index

SPEC.

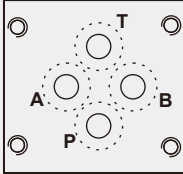
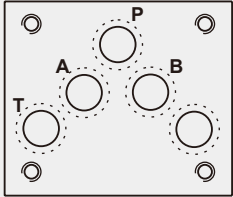
Size	02			03	
Model	4WE-06	DSG-02	DSG-02-AC24	4WE-10	DSG-03
Mounting Surfaces: General Patterns					
Mounting Surface	02; Cetop3; NG6			03; Cetop 5; NG10	
Max. Flow (l/min)	AC 60 DC 80	120	60	30-80	40-110
Max. Pressure (kgf/cm ²)	315	300	315	315	300
Tolerant Back Pressure (kgf/cm ²)	160	70~140	160	160	70~140
Switch Frequency	AC 120 DC 250	120	240	AC300 DC240	AC260 DC240
Operating Temperature	5~80°C (41~176°F)	5~60°C (41~140°F)	5~60°C (41~140°F)	5~80°C (41~176°F)	5~60°C (41~140°F)
Filtration Mesh	less than 25µm				
Page No.	6	18	26	12	22

4WE-06



ORDER CODES

4 WE - 6 - D O E - W220/50 - 10

1 2 3 4 5 6 7 8

1	▶ Number of Main Ports	3	3 main ports
		4	4 main ports
2	▶ Model Name	WE	
3	▶ Size	6	NG6 (Cetop3) 1/4" (02)
4	▶ Type of Valves	please refer to the symbol list (type of valves)	
5	▶ Spring Return	/	with spring return
		O	without spring return
		OF	without spring return with detent
6	▶ High-power Solenoid	E	wet-pin, with removable coil
7	▶ Power Source	G12	DC 12V
		G24	DC 24V
		W110/50	AC 110V, 50Hz
		W110/60	AC 110V, 60Hz
		W220/50	AC 220V, 50Hz
		W220/60	AC 220V, 60Hz
8	▶ Solenoid Appearance	10	plug-in connection

SYMBOL LIST (TYPE OF VALVES)

A			E		
C			G		
D			H		
			J		
B			L		
Y			M		
			P		
			T		
			U		

SECTION

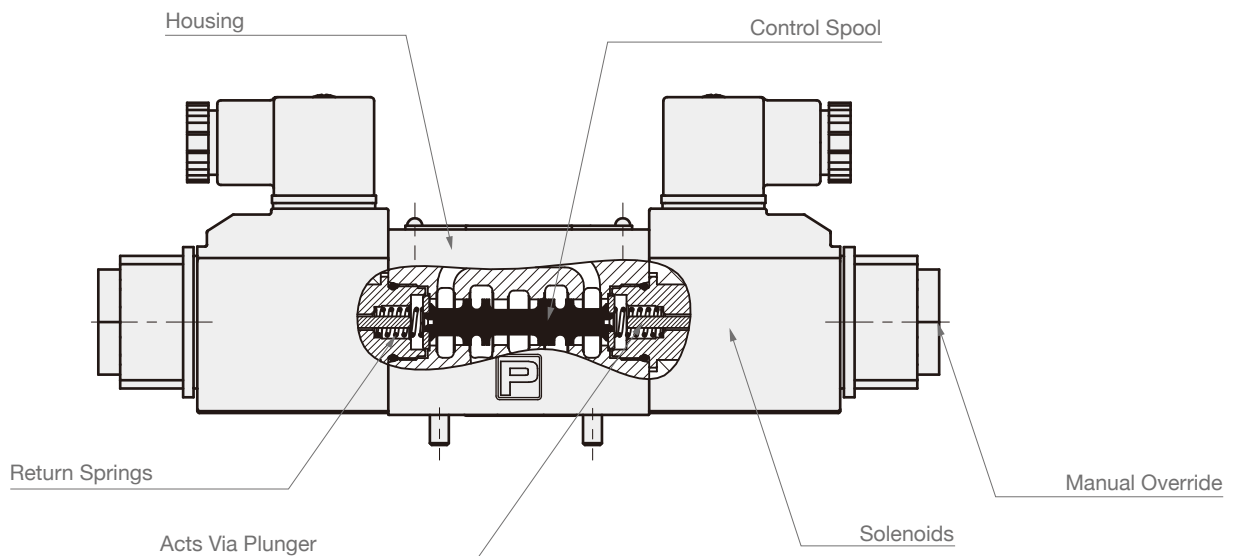

SPECIFICATIONS & PROPERTIES OF SOLENOID DIRECTIONAL VALVES

Orifice	Max. Flow (l/min)	Max. Pressure (kgf/cm ²)	Tolerant Back Pressure (kgf/cm ²)	Switch Frequency (times/min)	Weight (kg)			
					AC		DC	
					1 Solenoid	2 Solenoids	1 Solenoid	2 Solenoids
NG6 (Cetop3)	AC 60 DC 80	315	160	AC 120 DC 250	1.6	2.1	1.7	2.1

- Operating oil temperature: 5~80°C (41~176°F)
- Filtration mesh: less than 25µm

SPECIFICATIONS & PROPERTIES OF SOLENOIDS

Power Source	AC				DC	
Voltage	AC110V		AC220V		DC12V	DC24V
Hertz	50	60	50	60	-	-
Rated Force (N)	30				50	
Rated Stroke (mm)	3				3	
Total Stroke (mm)	6.5				≧ 6.5	
Duty Cycle (%)	100				100	
Insulation Class	H				B	
Power Consumption	≧ 28				32	
Inrush (VA)	≧ 66				32	
Voltage Tolerance	100~120		210~230		10.8~13.2	21.6~26.4
Holding Power (VA)	50				-	
Switch-On Power (VA)	220				-	

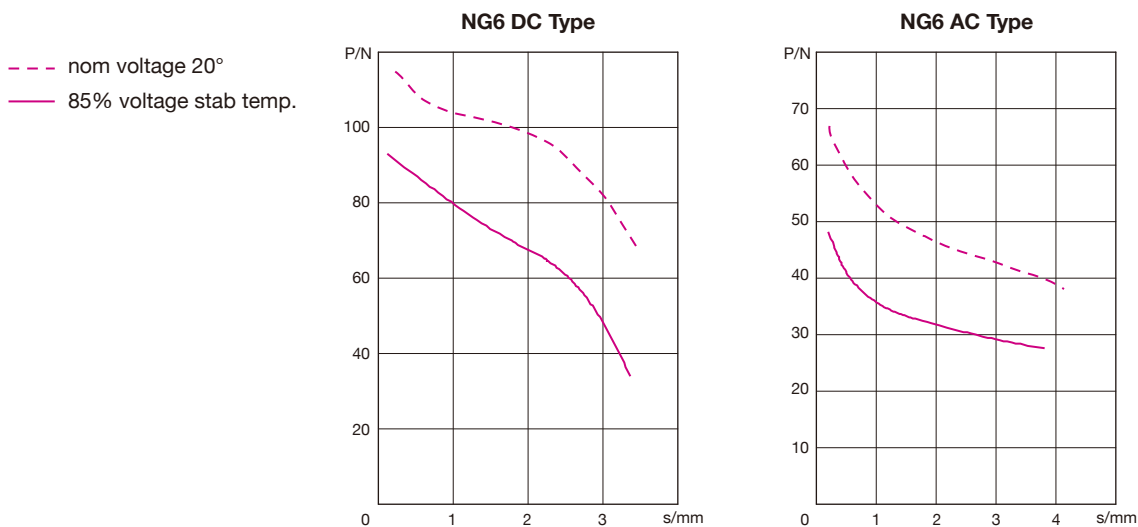

PERFORMANCE LIMITS

Measure at $v=41\text{mm}^2/\text{s}$ and $t=50^\circ\text{C}$

Attention:

The performance limits given are for applications featuring two flow directions (e.g. From P to A and simultaneous return flow from B to T). Due to the flow force active within the valves the permitted power limit for directional valves may be considerably less where there is only one direction of flow (e.g. from P to A and Port B is blocked)! (Please consult us for applications of this kind)

DC Solenoid G12 (DC 12V) G24 (DC 24V)		AC Solenoid W110 W220 50Hz W110 (AC 110V, 50Hz) W220 (AC 220V, 50Hz)		AC Solenoid W110 W220 60Hz W110 (AC 110V, 60Hz) W220 (AC 220V, 60Hz)	
Curve	Symbol	Curve	Symbol	Curve	Symbol
1	A, B	11	A, B	19	A, B
2	V	12	V	20	V
3	A, B	13	A, B	21	A, B
4	F, P	14	F, P	22	F, P
5	J	15	G, T	23	G, T
6	G, H, T	16	H	24	J, L, U
7	A/O, A/OF, L, U	17	A/O, A/OF, C/O, C/OF, D/O, D/OF, E, J, L, M, Q, R, U, W	25	A/O, A/OF, Q, W
8	C, D, Y			26	C, D, Y
9	M			27	H
10	E, R, C/O, C/OF, D/O, D/OF, Q, W	18	C, D, Y	28	C/O, C/OF, D/O, D/OF, E, M, R

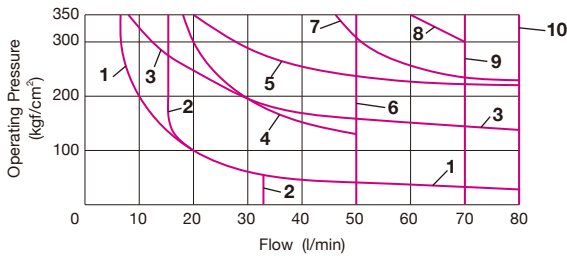

DC Solenoid	
Curve	
1 ~ 10	

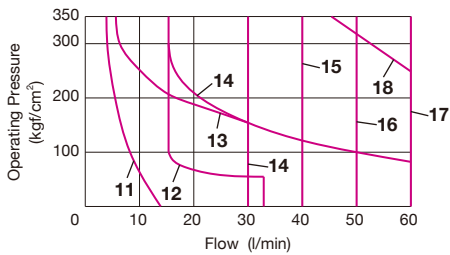

AC Solenoid		
Curve	Solenoid Cross Reference	
11 ~ 18	W110	110V, 50Hz
	W220	220V, 50Hz

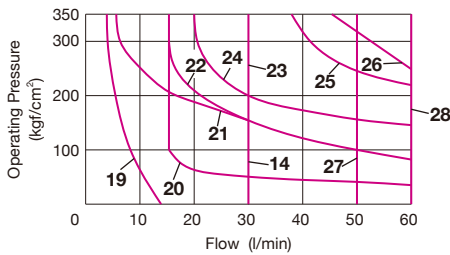

AC Solenoid		
Curve	Solenoid Cross Reference	
19 ~ 28	W110	110V, 60Hz
	W220	220V, 60Hz

CHARACTERISTIC CURVES

Measure at $v=41\text{mm}^2/\text{s}$ and $t=50^\circ\text{C}$

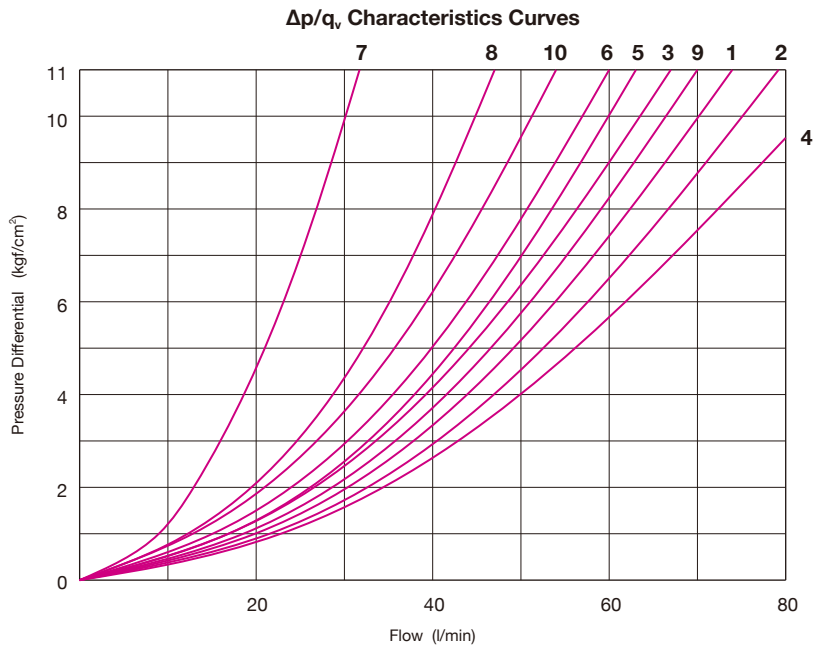

Symbol	Flow Direction			
	P → A	P → B	A → T	B → T
A, B	3	3	-	-
C	1	1	3	1
D, Y	5	5	3	3
E	3	3	1	1
F	1	3	1	1
T	10	10	9	9
H	2	4	2	2
J, Q	1	1	2	1
L	3	3	4	9
M	2	4	3	3
P	3	1	1	1
R	5	5	4	-
V	1	2	1	1
W	1	1	2	2
U	3	3	9	4
G	6	6	9	9
A, B	3	3	-	-

► **NG6 DC Type**

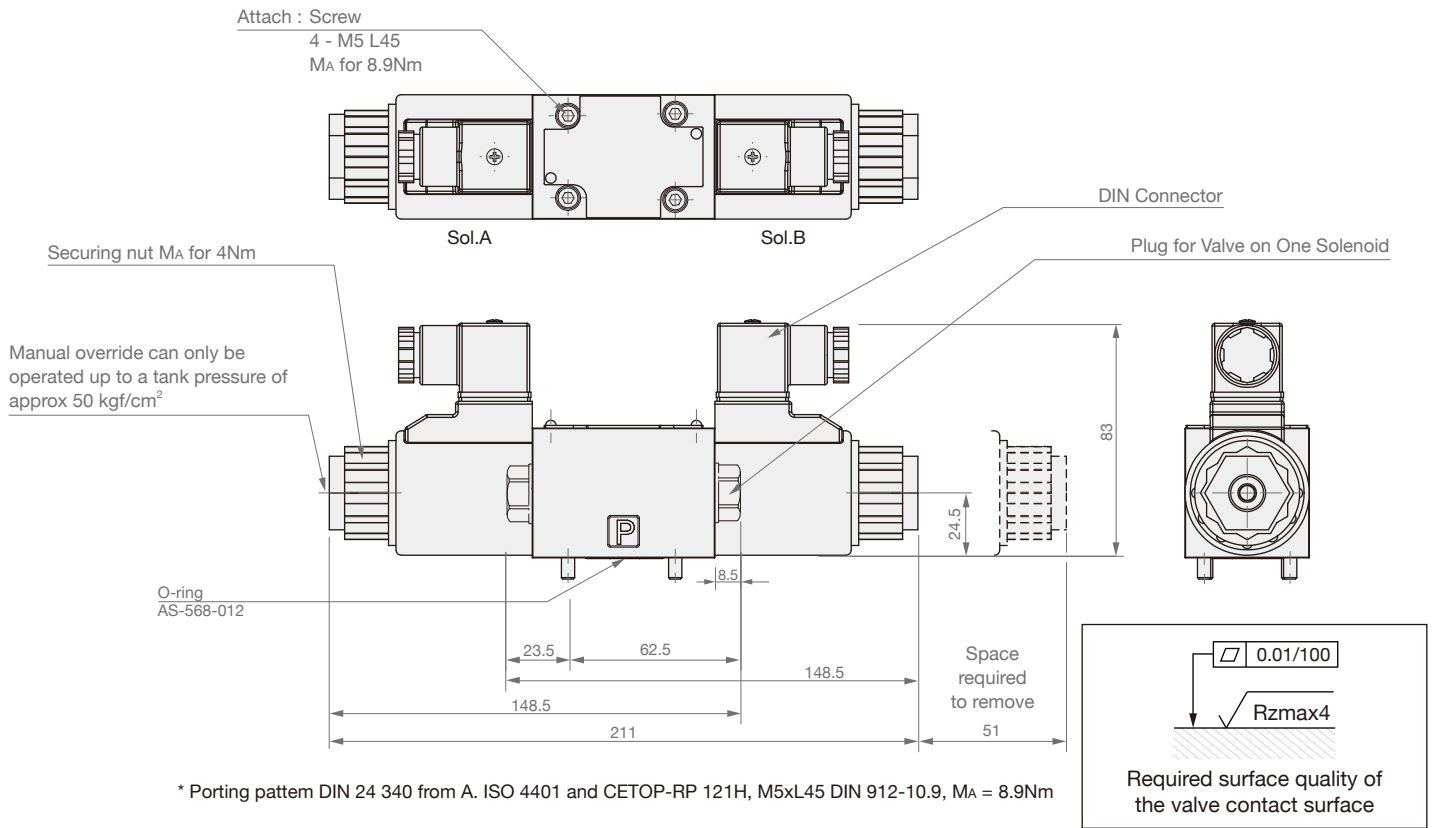

► **NG6 AC Type**

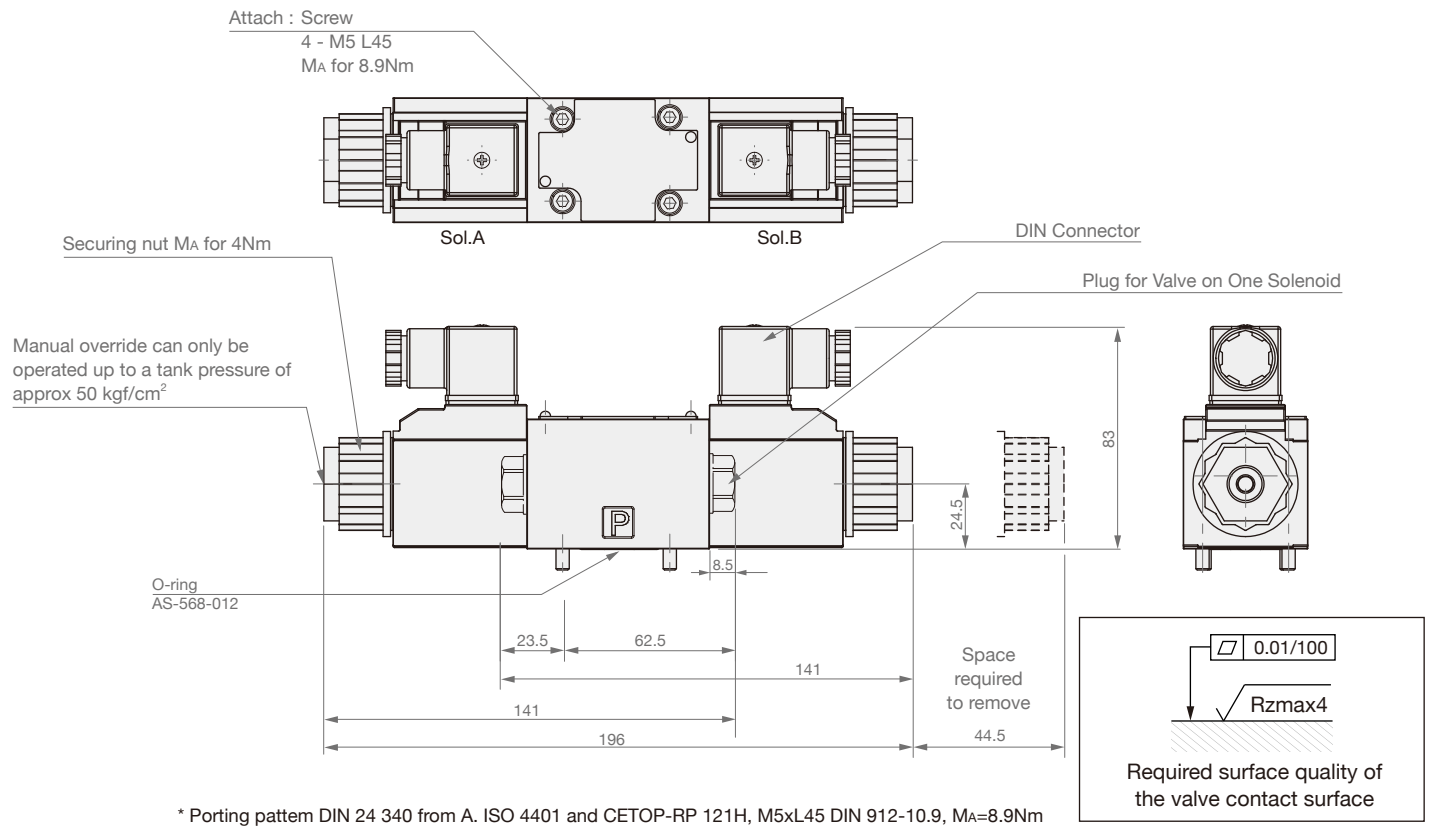

4WE-10

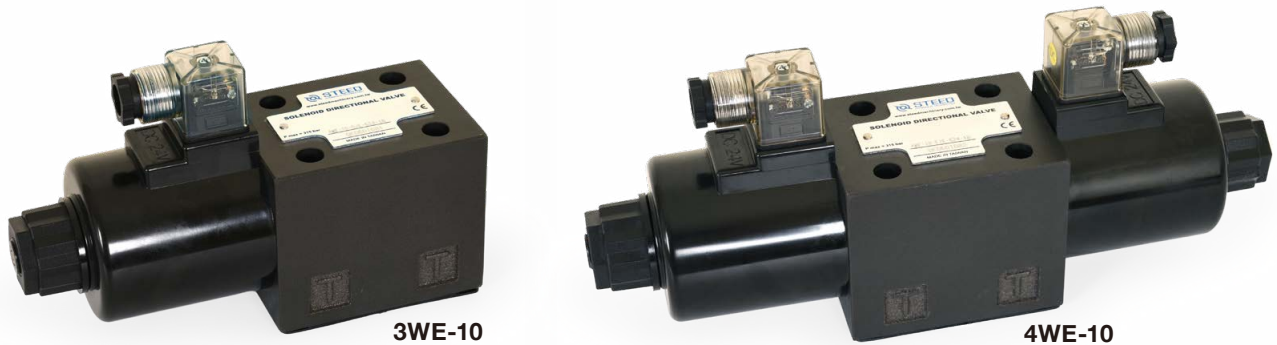

ORDER CODES

4 WE - 10 - J / E - G24 - 10

1	▶ Number of Main Ports	3	3 main ports
		4	4 main ports
2	▶ Model Name	WE	
3	▶ Size	10	NG6 (Cetop5) 3/8" (03)
4	▶ Type of Valves	please refer to the symbol list (type of valves)	
5	▶ Spring Return	/	with spring return
		O	without spring return
		OF	without spring return with detent
6	▶ High-power Solenoid	E	wet-pin, with removable coil
7	▶ Power Source	G12	DC 12V
		G24	DC 24V
		W110/50	AC 110V, 50Hz
		W110/60	AC 110V, 60Hz
		W220/50	AC 220V, 50Hz
		W220/60	AC 220V, 60Hz
8	▶ Solenoid Appearance	10	plug-in connection

SYMBOL LIST (TYPE OF VALVES)

A			E		
C			G		
D			H		
			J		
B			L		
Y			M		
			P		
			T		
			U		

SECTION

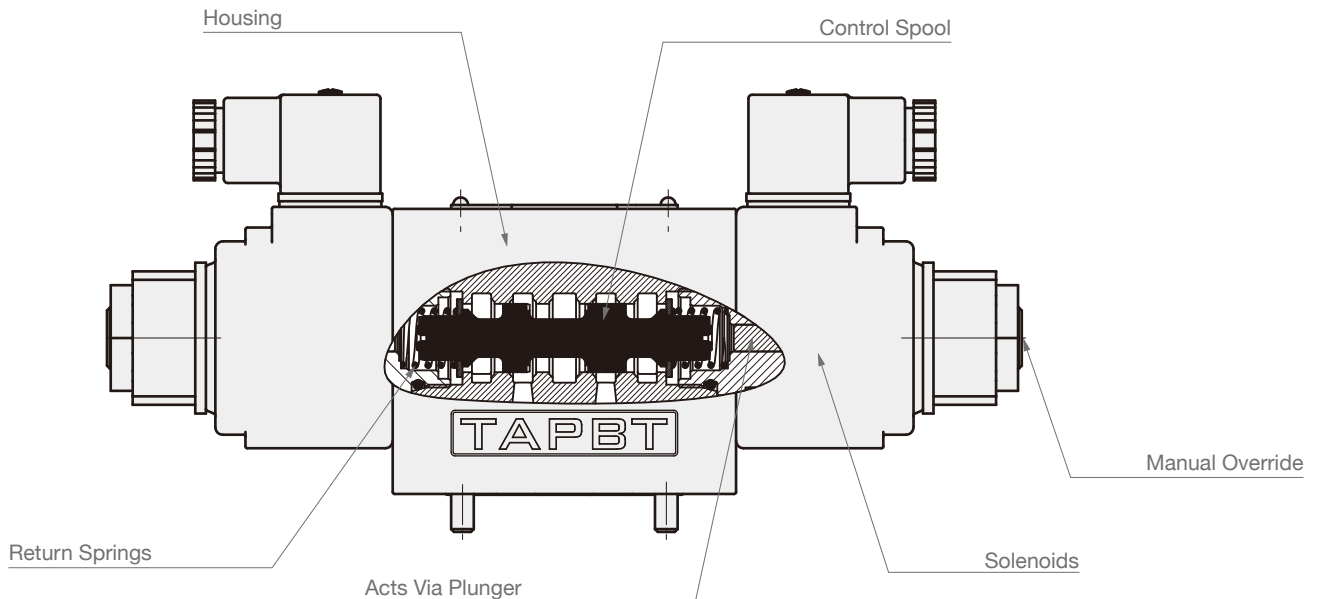

SPECIFICATIONS & PROPERTIES OF SOLENOID DIRECTIONAL VALVES

Orifice	Max. Flow (l/min)	Max. Pressure (kgf/cm ²)	Tolerant Back Pressure (kgf/cm ²)	Switch Frequency (times/min)	Weight (kg)			
					AC		DC	
					1 Solenoid	2 Solenoids	1 Solenoid	2 Solenoids
NG10 (Cetop5)	120	315	160	120	3.6	4.3	4.3	5.5

- Operating oil temperature: 5~80°C (41~176°F)
- Filtration mesh: less than 25µm

SPECIFICATIONS & PROPERTIES OF SOLENOIDS

Power Source	AC				DC	
Voltage	AC110V		AC220V		DC12V	DC24V
Hertz	50	60	50	60	-	-
Rated Force (N)	54				100	
Rated Stroke (mm)	4				3.6	
Total Stroke (mm)	8.5				8.5	
Duty Cycle (%)	100				100	
Insulation Class	H				B	
Power Consumption	38				36	
Inrush (VA)	71				36	
Voltage Tolerance	100~120		210~230		10.8~13.2	21.6~26.4
Holding Power (VA)	90				-	
Switch-On Power (VA)	550				-	

NG10 DC Type

- nom voltage 20°
- 85% voltage stab temp.

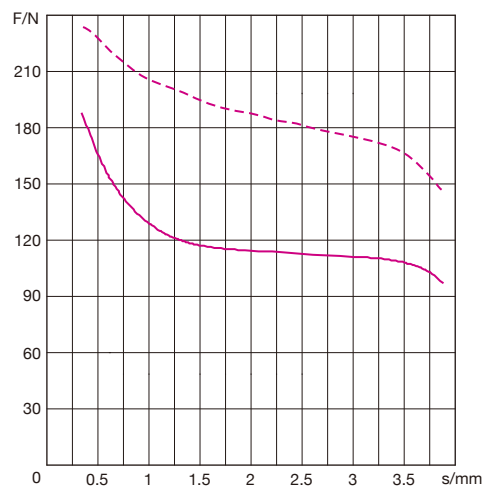

NG10 AC Type

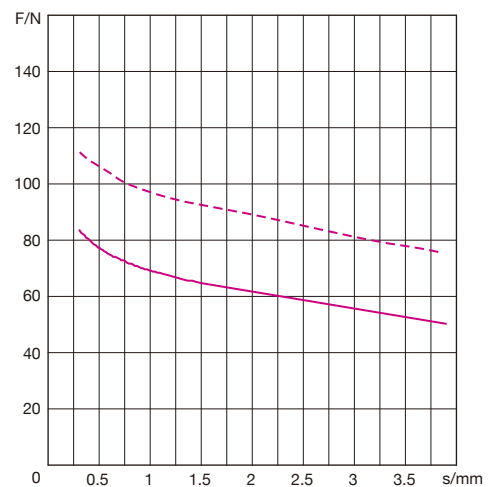

PERFORMANCE LIMITS

Measure at $v=41\text{mm}^2/\text{s}$ and $t=50^\circ\text{C}$

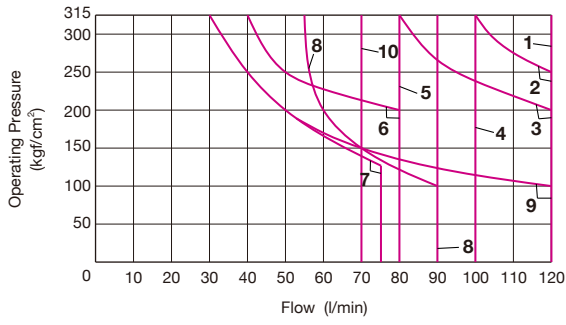

DC Solenoid	
Curve	Symbol
1	C, C/O, C/OF, D, D/O, D/OF, Y, M
2	E
3	A/O, A/OF, L, U, J, Q, W
4	H
5*	R
6	G
7	T
8	F, P
9	A, B
10	V

* Return flow (independent of area ratio)

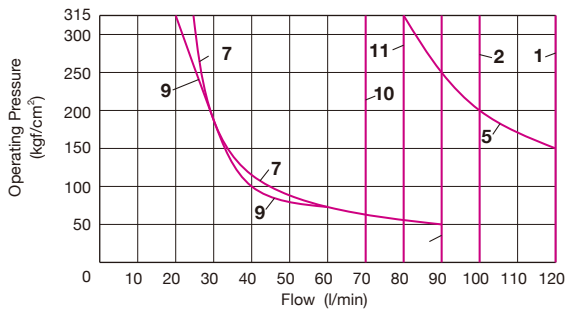

AC Solenoid 110V, 50Hz; 120V, 60Hz 220V, 50Hz; 240V, 60Hz	
Curve	Symbol
1	C, C/O, C/OF, D, D/O, D/OF, Y
2	E, L, U, Q, W
3	M
4	A, B
5*	A/O, A/OF, J
6	G
7	F, P
8	V
9	T
10	H
11	R

* Return flow (independent of area ratio)

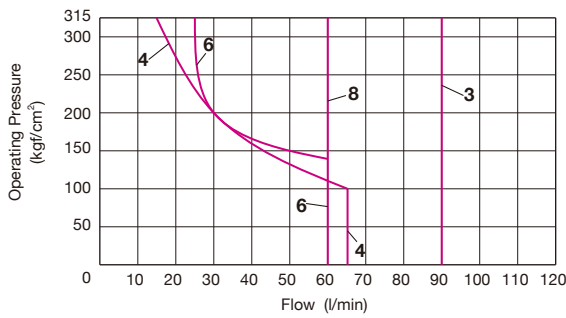

AC Solenoid 110V, 60Hz 220V, 60Hz	
Curve	Symbol
1	C, C/O, C/OF, D, D/O, D/OF, Y
2, 3	A/O, A/OF, E
4	M
5	V
6	H

CHARACTERISTIC CURVES

Measure at $v=41\text{mm}^2/\text{s}$ and $t=50^\circ\text{C}$

$\Delta p/q_v$ Characteristics Curves

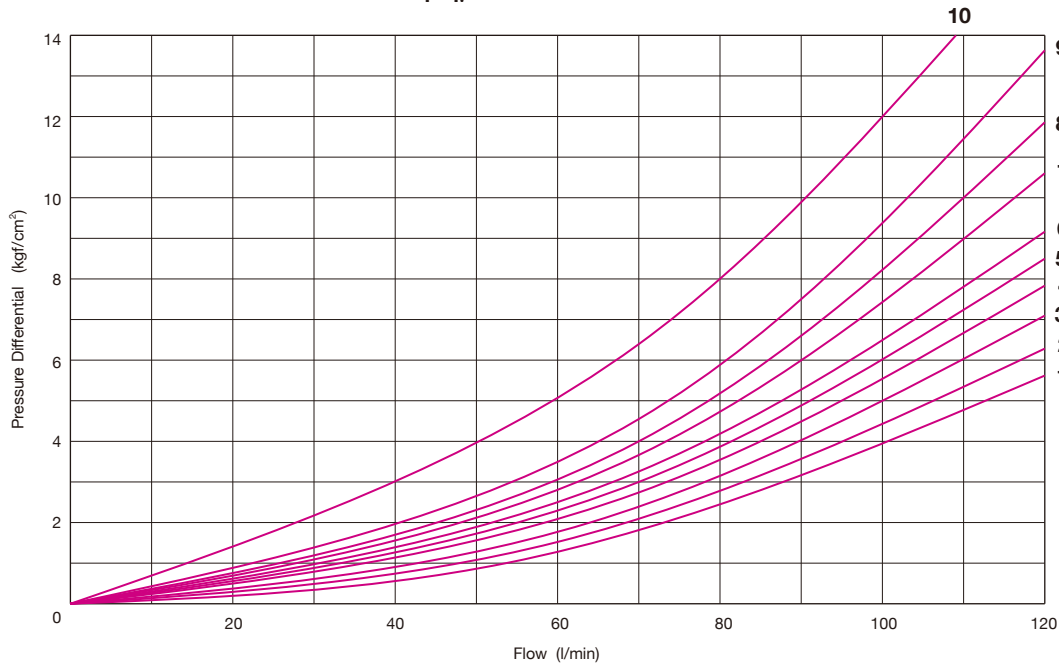

Symbol	Flow Direction			
	P → A	P → B	A → T	B → T
A, B	3	3	-	-
C	3	3	4	5
D, Y	5	5	6	6
E	1	1	4	4
F	2	3	7	4
G	3	3	6	7
H	1	1	6	7
J	1	1	3	3
L	2	2	3	5
M	1	1	4	5
P	4	2	5	7
Q	1	2	1	3
R	3	6	4	-
T	3	3	6	7
U, V	2	2	3	3
W	2	2	4	5

OP.POS.	P → A	P → B	A → T	B → T
R	-	9	-	-

MID. POS.					
	P → A	P → B	B → T	A → T	P → T
F	4	-	-	9	9
P	-	5	8	-	10
G, T	-	-	-	-	9
H	-	-	-	-	3

► **NG10 DC Type**

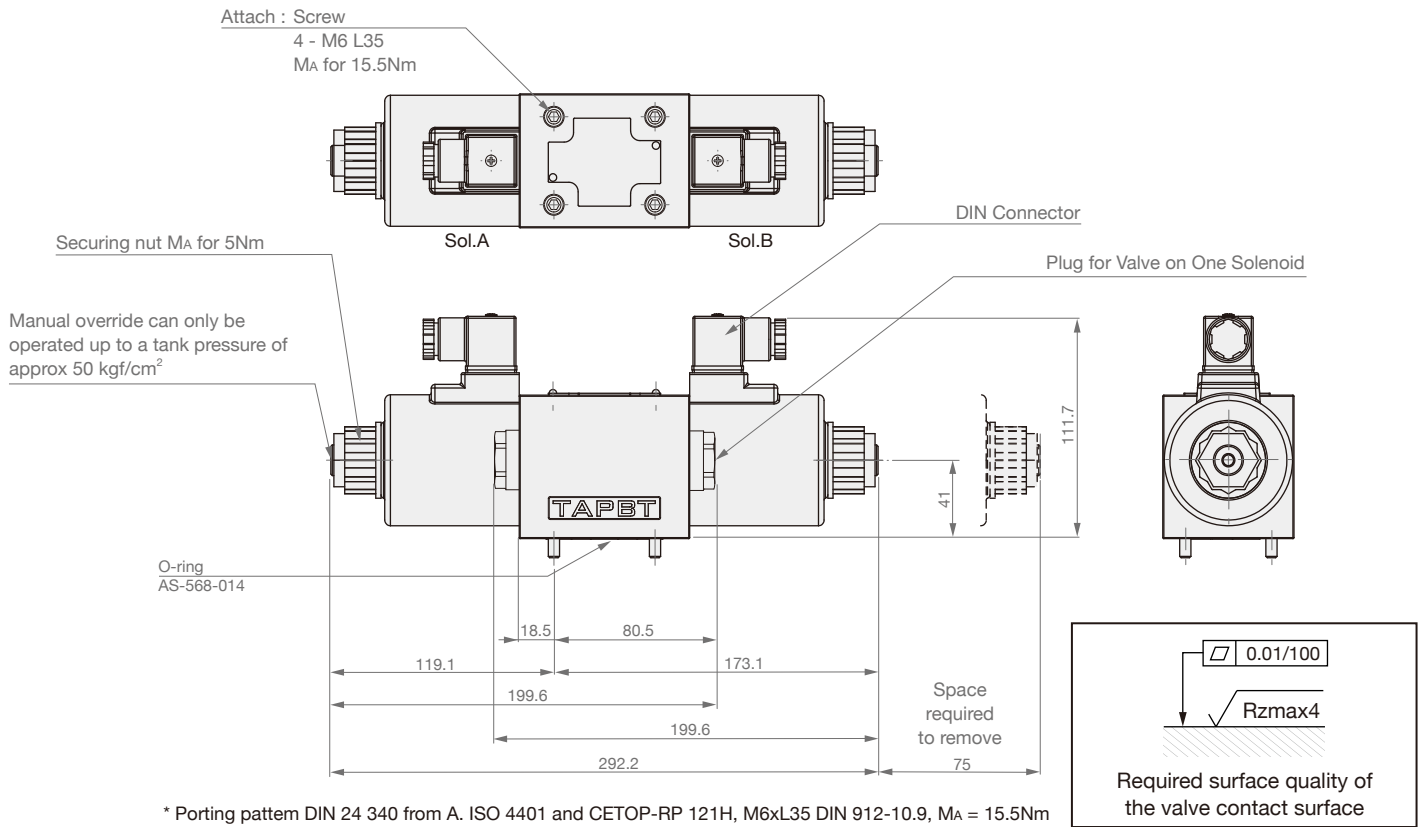

► **NG10 AC Type**

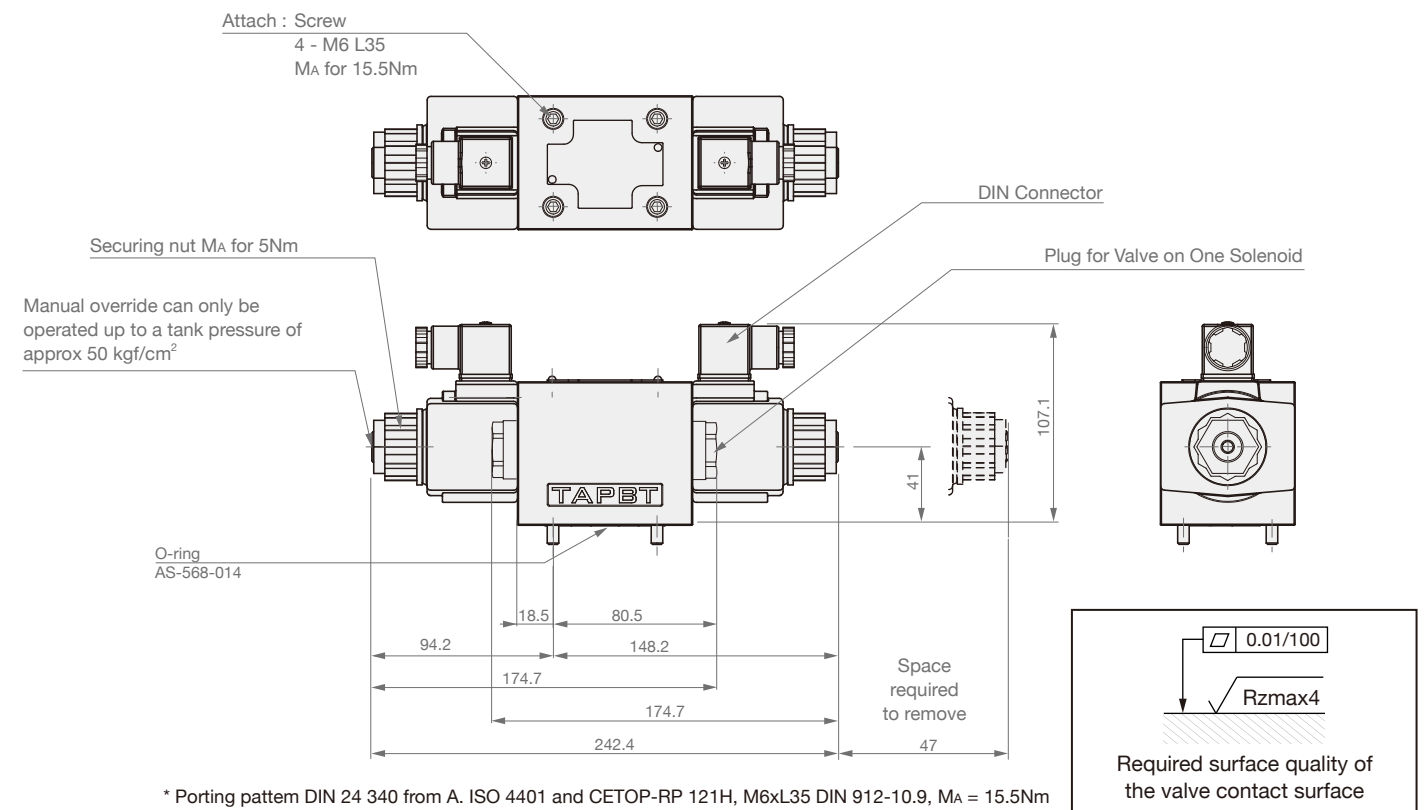

DSG-02



DSG-02B-2B



DSG-02B-3C

ORDER CODES

DSG - 02 B - 3C2 - A1

1
2
3
4
5

1	Model Name	DSG	
2	Thread Connection	02	1/4"
3	Solenoid Appearance	A	terminal box type
		B	DIN connector type
		C	wiring type
4	Type of Valves	please refer to the symbol list (type of valves)	
5	Power Source	A1	AC110V, 50/60Hz
		A2	AC220V, 50/60Hz
		D1	DC12V
		D2	DC24V

SYMBOL LIST (TYPE OF VALVES)

Double Solenoids Three Positions with Springs	Single Solenoid Two Positions with Spring	Single Solenoid Two Positions with Spring (Reverse Combination)	Single Solenoid Two / Three Positions with Spring	Single Solenoid Two / Three Positions with Spring (Reverse Combination)
3C2	2B2B	2B2BL	2B2	2B2L
3C3	2B3B	2B3BL	2B3	2B3L
3C4	2B4B	2B4BL	2B8	2B8L
3C5	2B5B	2B5BL	2B2A	2B2AL
3C60	2B60B	2B60BL	2B3A	2B3AL
3C9	2B9B	2B9BL	2B12A	2B12AL
3C10	2B10B	2B10BL	Single Solenoid Two Positions without Spring	
3C11	2B11B	2B11BL	2D3	
3C12	2B12B	2B12BL	2D8	
3C25	2B25B	2B25BL		

SPECIFICATIONS & PROPERTIES OF SOLENOID DIRECTIONAL VALVES

Orifice	Max. Flow (l/min)	Max. Pressure (kgf/cm ²)	Tolerant Back Pressure (kgf/cm ²)	Switch Frequency (times/min)	Weight (kg)			
					AC		DC	
					1 Solenoid	2 Solenoids	1 Solenoid	2 Solenoids
02 (1/4")	30-80	300	70-140	AC300 DC240	1.6	2	1.8	2.2

- Operating oil temperature: 5~60°C (41~140°F)
- Filtration mesh: less than 25µm

SPECIFICATIONS & PROPERTIES OF SOLENOIDS

Power Source		AC				DC	
Voltage		AC110V		AC220V		DC12V	DC24V
Hertz		50	60	50	60	-	-
02 (1/4")	Starting Current (A)	1.4	1.2	0.7	0.6	2.4	1.3
	Operating Current (A)	0.4	0.34	0.2	0.7		
Voltage Tolerance		100~120		200~240		10.8~13.2	21.6~26.4

- Over 100MΩ mega-OHMS
- Caution : In case the solenoid was burned up.
 1. For double solenoid valves don't energize both at the same time as it will result in solenoids burning out.
 2. Avoid energizing solenoid valves, while the solenoids are not installed to the tubes.

CHARACTERISTIC CURVES

Based on mineral oil ISO VG 32 and t=50°C

Spool Type	Flow Direction				
	P → A	P → B	A → T	B → T	P → T
3C2	2	2	2	2	-
3C3	1	1	1	1	1
3C4	2	2	1	1	-
3C5	1	5	2	4	3
3C60	5	5	4	4	3
3C9	1	1	2	2	-
3C11	1	2	2	2	-
3C12	2	2	1	2	-
2D2	2	2	2	2	-
2D3	1	1	1	1	-
2B2	2	2	2	2	-
2B3	1	1	1	1	-

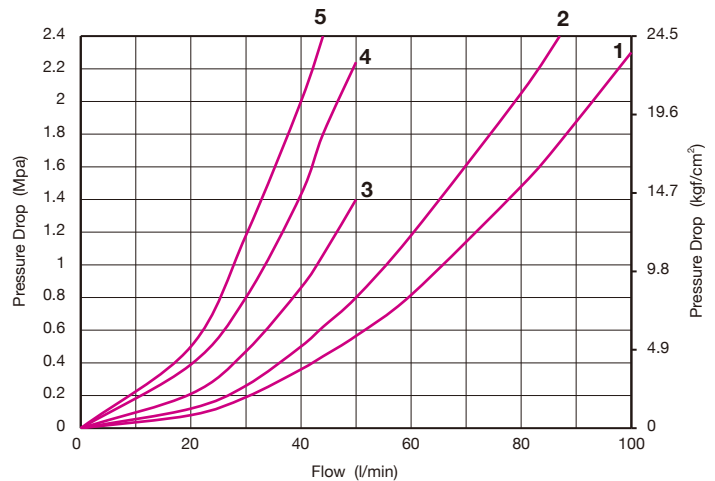

► DSG-02B-2B*-A*

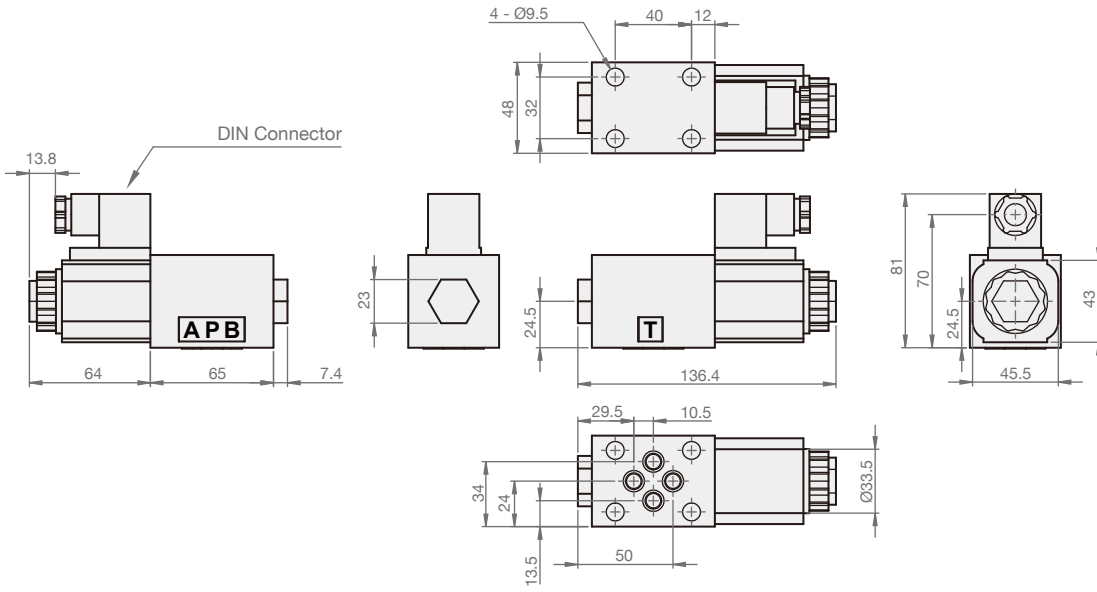

► DSG-02B-2B*-D*

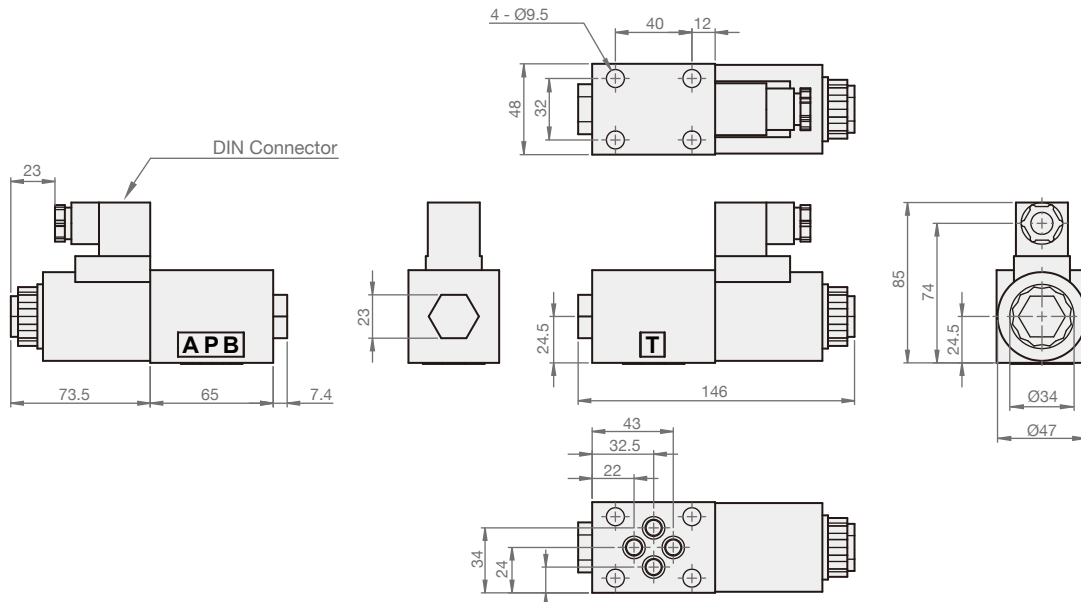

DSG-03



DSG-03B-2B



DSG-03B-3C

ORDER CODES

DSG - 03 B - 3C60 - D2

1 2 3 4 5

1	Model Name	DSG	
2	Thread Connection	03	3/8"
3	Solenoid Appearance	A	terminal box type
		B	DIN connector type
		C	wiring type
4	Type of Valves	please refer to the symbol list (type of valves)	
5	Power Source	A1	AC110V, 50/60Hz
		A2	AC220V, 50/60Hz
		D1	DC12V
		D2	DC24V

SYMBOL LIST (TYPE OF VALVES)

Double Solenoids Three Positions with Springs	Single Solenoid Two Positions with Spring	Single Solenoid Two Positions with Spring (Reverse Combination)	Single Solenoid Two / Three Positions with Spring	Single Solenoid Two / Three Positions with Spring (Reverse Combination)
3C2	2B2B	2B2BL	2B2	2B2L
3C3	2B3B	2B3BL	2B3	2B3L
3C4	2B4B	2B4BL	2B8	2B8L
3C5	2B5B	2B5BL	2B2A	2B2AL
3C60	2B60B	2B60BL	2B3A	2B3AL
3C9	2B9B	2B9BL	2B12A	2B12AL
3C10	2B10B	2B10BL	Single Solenoid Two Positions without Spring	
3C11	2B11B	2B11BL	2D3	
3C12	2B12B	2B12BL	2D8	
3C25	2B25B	2B25BL		

SPECIFICATIONS & PROPERTIES OF SOLENOID DIRECTIONAL VALVES

Orifice	Max. Flow (l/min)	Max. Pressure (kgf/cm ²)	Tolerant Back Pressure (kgf/cm ²)	Switch Frequency (times/min)	Weight (kg)			
					AC		DC	
					1 Solenoid	2 Solenoids	1 Solenoid	2 Solenoids
03 (3/8")	40-110	300	70-140	AC260 DC240	3.3	4.2	3.6	4.7

- Operating oil temperature: 5~60°C (41~140°F)
- Filtration mesh: less than 25µm

SPECIFICATIONS & PROPERTIES OF SOLENOIDS

Power Source		AC				DC	
Voltage		AC110V		AC220V		DC12V	DC24V
Hertz		50	60	50	60	-	-
03 (3/8")	Starting Current (A)	3.25	2.8	1.66	1.4	2.1	1.05
	Operating Current (A)	0.65	0.56	0.33	0.28		
Voltage Tolerance		100~120		200~240		10.8~13.2	21.6~26.4

- Over 100MΩ mega-OHMS
- Caution : In case the solenoid was burned up.
 1. For double solenoid valves don't energize both at the same time as it will result in solenoids burning out.
 2. Avoid energizing solenoid valves, while the solenoids are not installed to the tubes.

CHARACTERISTIC CURVES

Based on mineral oil ISO VG 32 and t=50°C

Spool Type	Flow Direction				
	P → A	P → B	A → T	B → T	P → T
3C2	6	6	6	6	-
3C3	7	7	7	7	5
3C4	6	7	6	7	-
3C5	5	2	2	5	8
3C60	1	1	1	1	4
3C9	7	6	7	6	-
3C11	7	6	6	6	-
3C12	6	6	6	7	-
2B2	2	2	6	6	-
2B3	3	3	6	6	-

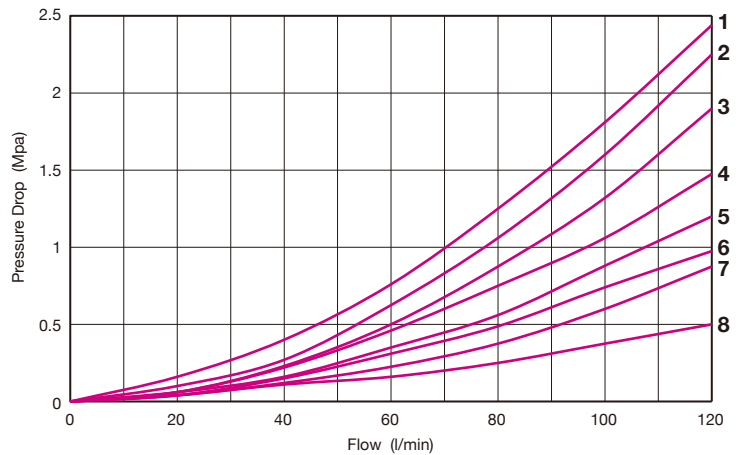

► DSG-03B-2B*-A*

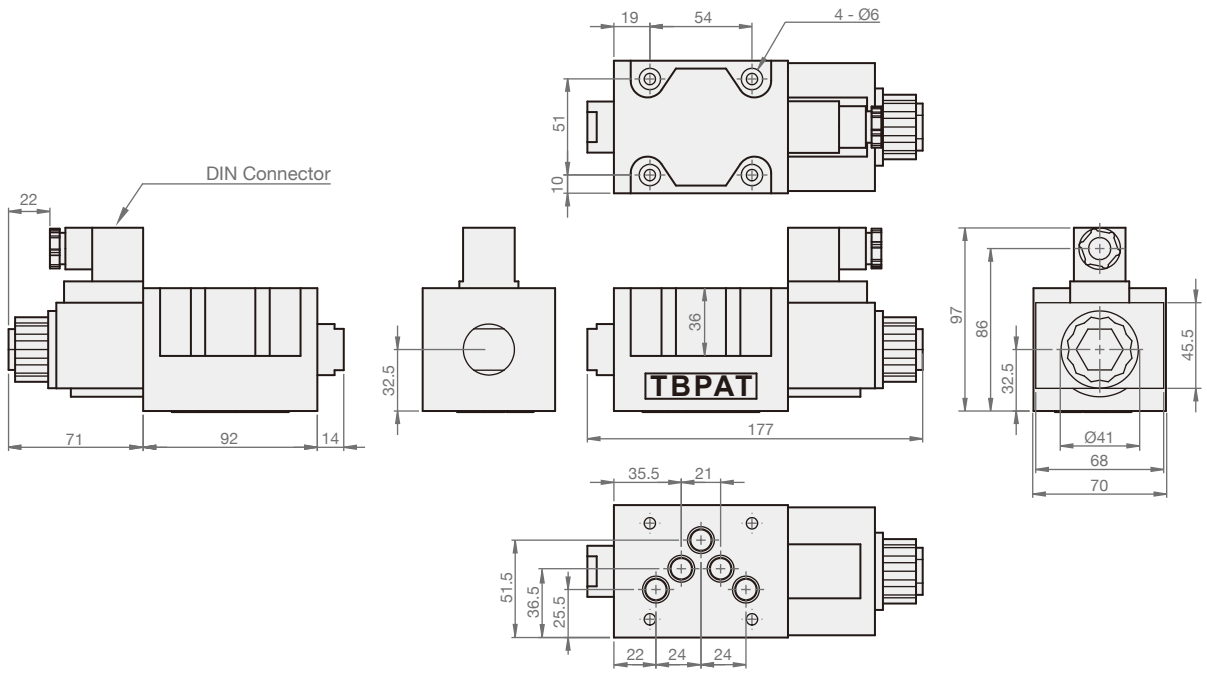

► DSG-03B-2B*-D*

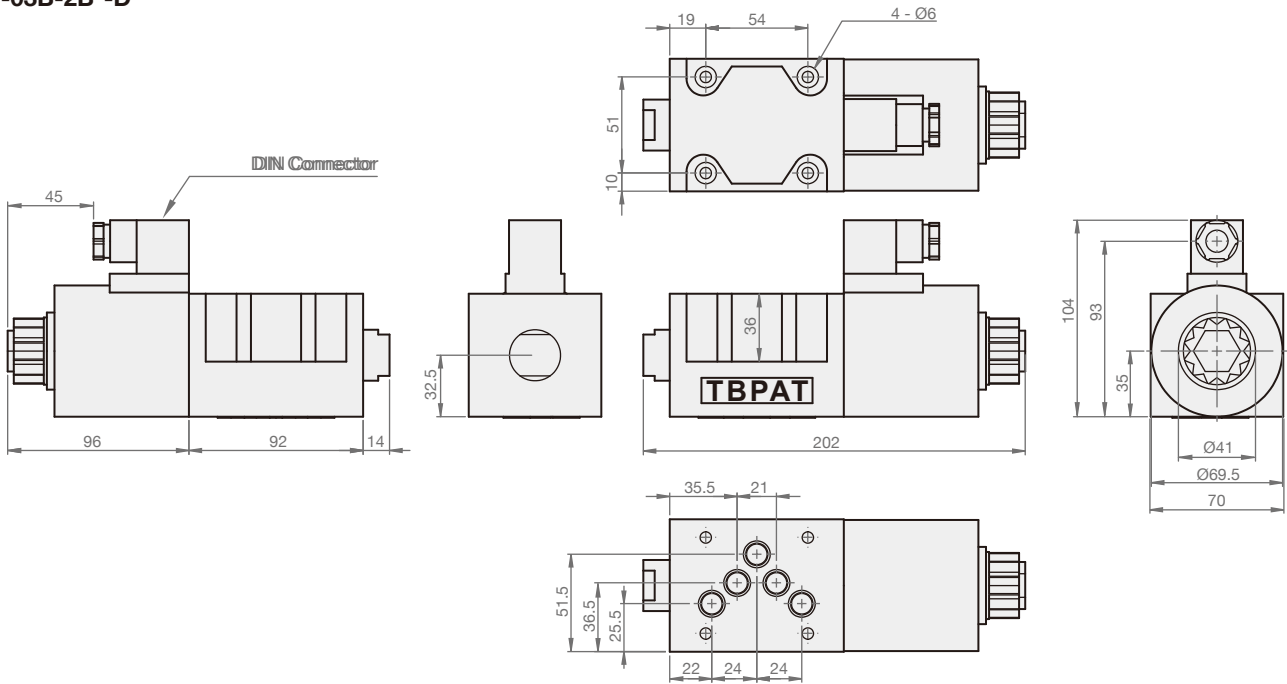

► **DSG-03B-3C*-A***

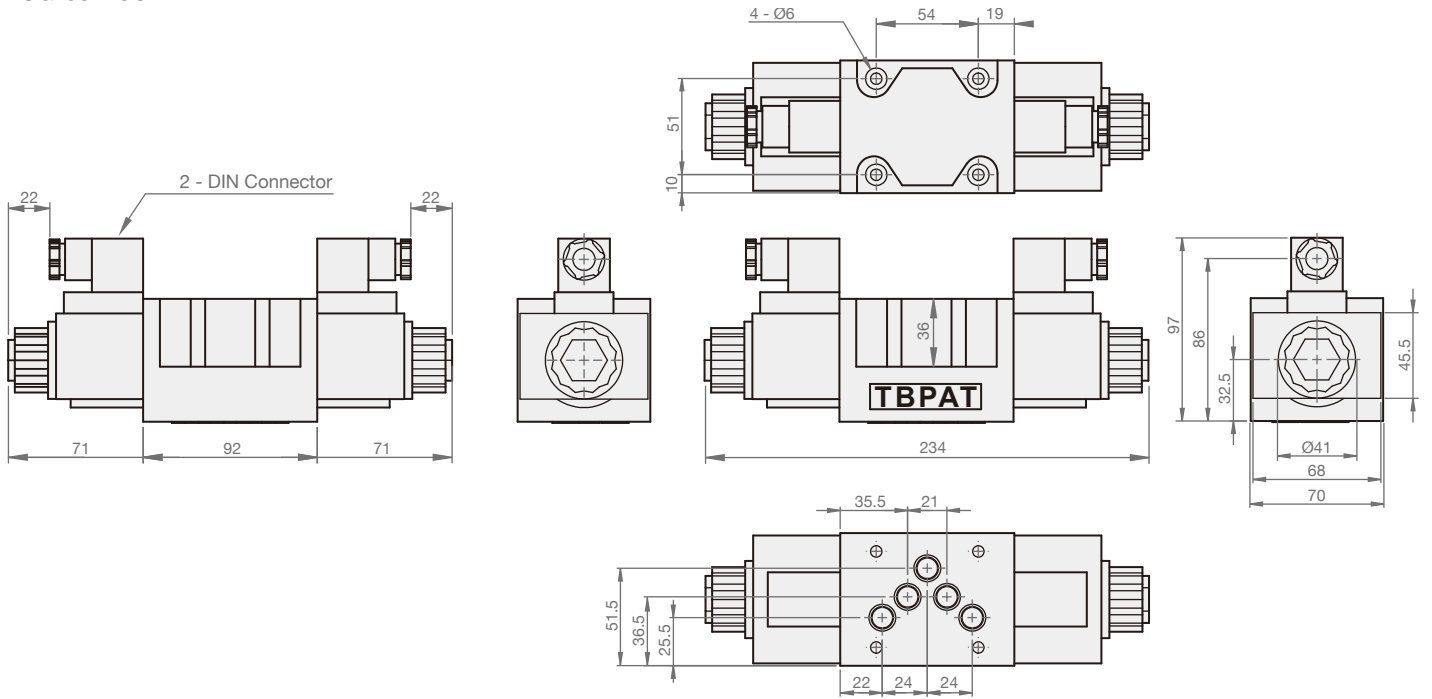

► **DSG-03B-3C*-D***

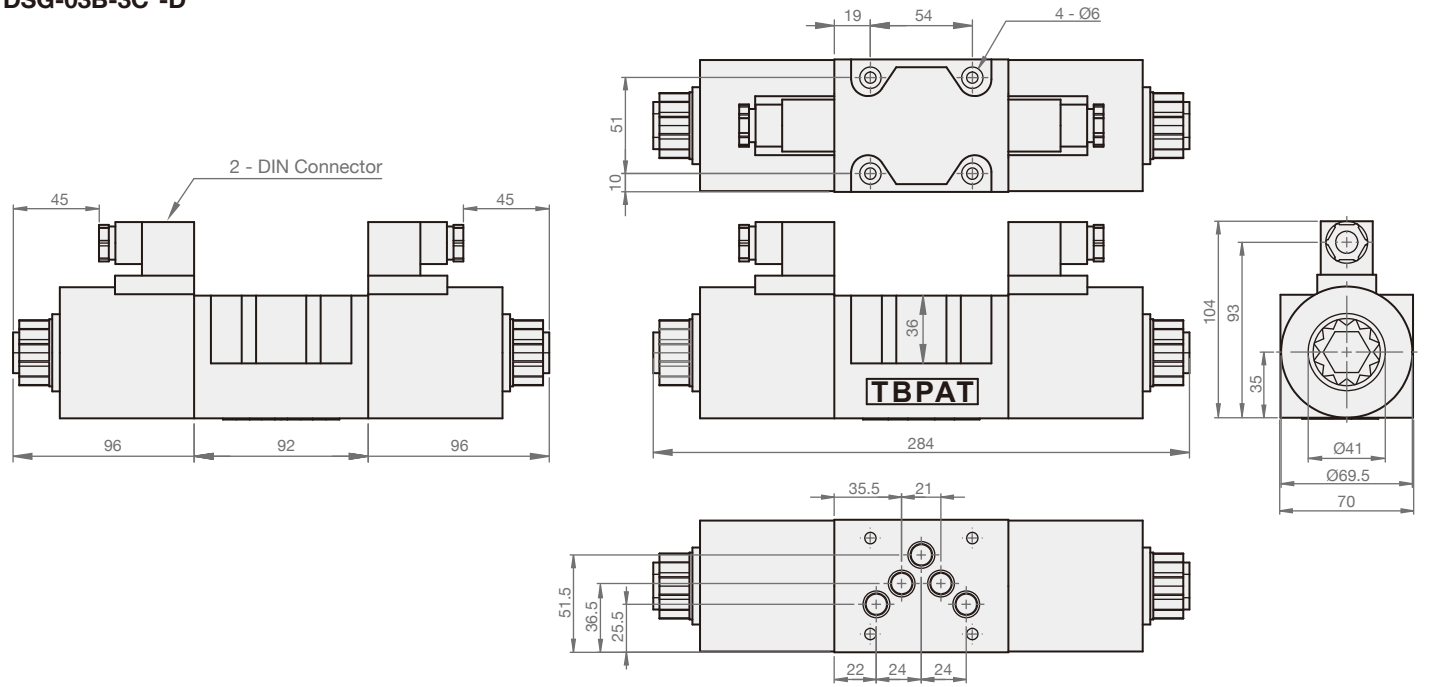

DSG-02-AC24



ORDER CODES

DSG - **02** - **3C25** - **AC24** **N**

1 2 3 4 5

1 ▶	Model Name	DSG	
2 ▶	Thread Connection	02	1/4"
3 ▶	Type of Valves	please refer to the symbol list (type of valves)	
4 ▶	Power Source	AC24	AC24V, 50Hz
5 ▶	Solenoid Appearance	N	DIN connector
		none	terminal box type

MODEL SPEC.

Model		DSG-02-AC24
Max. Pressure (P, A, B Port)	normal type	31.5 Mpa
	spool type: 3C5, 3C60	25 Mpa
Permissible Back Pressure (T Port)		16 Mpa
Max. Switch Frequency		240 cycle/min
Max. Flow		60 l/min
Operating Fluid Temp. Range		5 ~ 60 °C (40 ~ 140 °F)
Viscosity Range		20 ~ 300 cSt
Filtration Required		25µm
Weight	1 Solenoid	AC : 1.6 DC, RF : 1.9
	2 Solenoids	AC : 2.0 DC, RF : 2.2

SPECIFICATIONS & PROPERTIES OF SOLENOIDS

Model	DSG-02-AC24
Voltage	AC24V
Frequency	50Hz
In-rush Current	1.45A
Holding Current	041A
Voltage Tolerance	Sol. can used for nom. volt. with ±10% of the coil.
Insulation Resistance	Over than 100MΩ mega-OHMS

SYMBOL LIST (TYPE OF VALVES)

Single Coil, Two Positions with Spring Return (standard)		Single Coil, Two Positions with Spring Return (reverse)		Single Coil, Two Positions with Spring Return (standard)		Single Coil, Two Positions with Spring Return (reverse)	
2B2A		2B2AL		2B2B		2B2BL	
2B3A		2B3AL		2B3B		2B3BL	
2B4A		2B4AL		2B4B		2B4BL	
2B40A		2B40AL		2B40B		2B40BL	
2B5A		2B5AL		2B5B		2B5BL	
2B60A		2B60AL		2B60B		2B60BL	
2B7A		2B7AL		2B7B		2B7BL	
2B8A		2B8AL		2B8B		2B8BL	
2B9A		2B9AL		2B9B		2B9BL	
2B10A		2B10AL		2B10B		2B10BL	
2B11A		2B11AL		2B11B		2B11BL	
2B12A		2B12AL		2B12B		2B12BL	
Double Coils, Three Positions, with Spring		Double Coils, Two Positions, without Spring		Double Coils, Two Positions, without Spring			
3C2		2D2		2D2A			
3C3		2D3		2D3A			
3C4		2D7		2D4A			
3C40		2D8		2D40A			
3C5		Single Coil, Two Positions with Spring Return (standard)		2D5A			
3C60				2D7A			
3C7		2B2		2D9A			
3C8		2B3		2D10A			
3C9		2B8		2D11A			
3C10		Single Coil, Two Positions with Spring Return (reverse)		2D12A			
3C11							
3C12		2B2L					
		2B3L					
		2B8L					

► **DSG-02-AC24N**

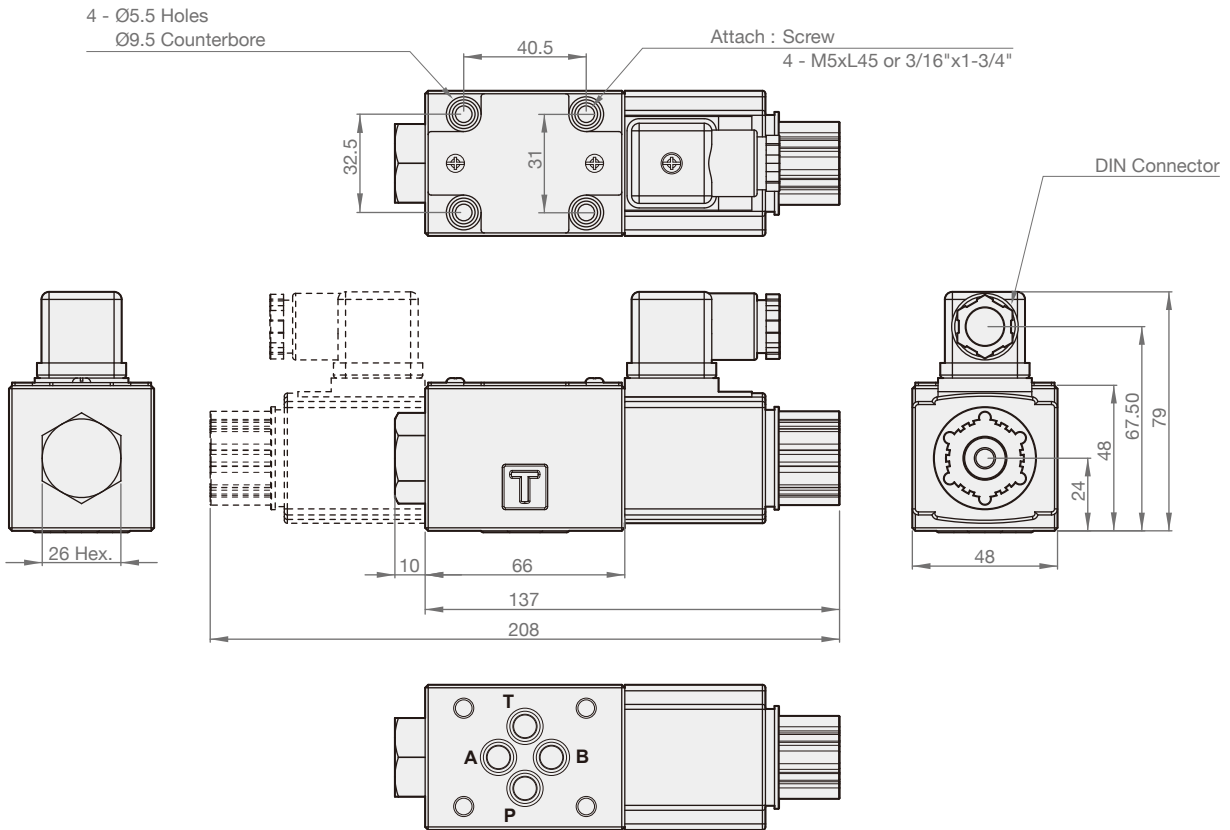

► **DSG-02-AC24**

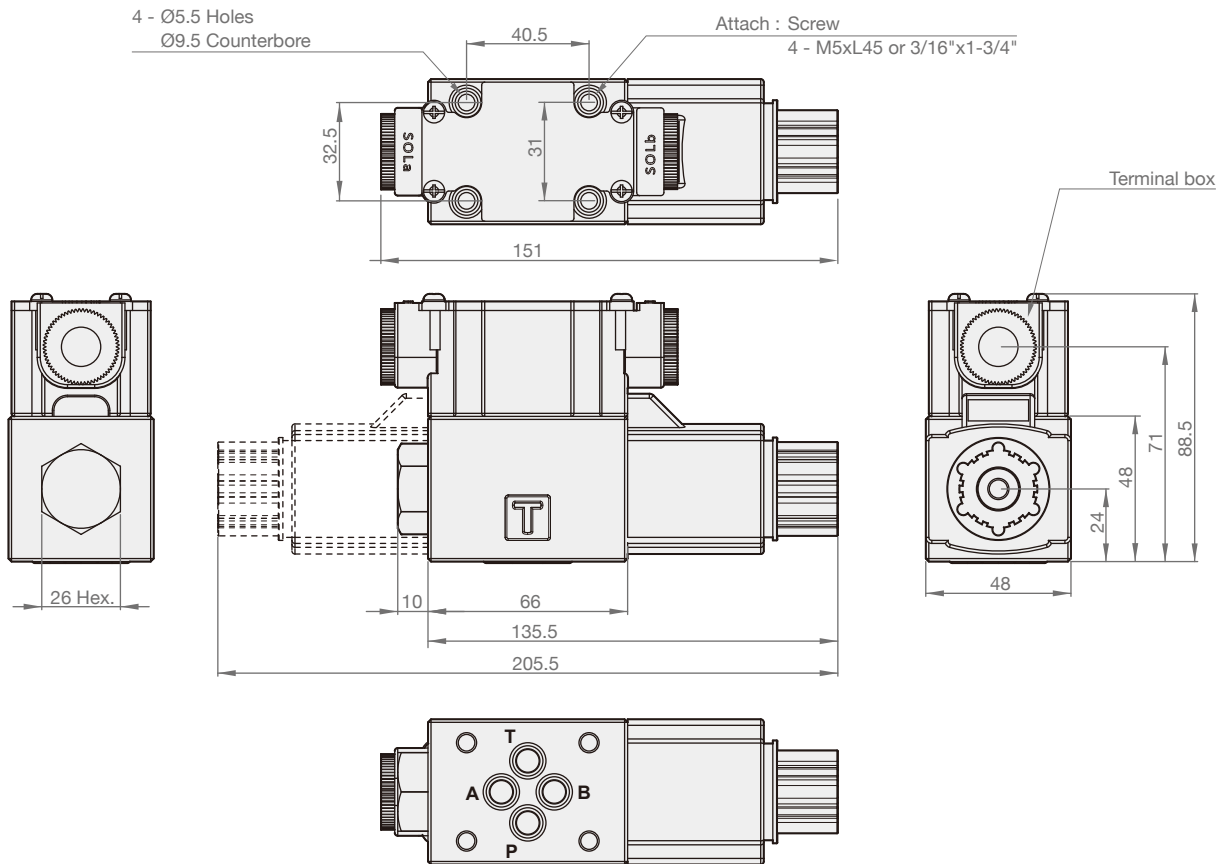

DHG



DHG-04



DHG-06

ORDER CODES

DH **G** - **04** - **3C2** - **ET** - **AB** - **K**

1 2 3 4 5 6 7

1 ▶	Model Name	DH	
2 ▶	Mounting	G	sub-plate mounted
3 ▶	Thread Connection	04	PT 1/2"
		06	PT 3/4"
4 ▶	Spool Type	please refer to the symbol list	
5 ▶	Drain Type	none	pilot oil supply internal, pilot oil drain internal
		T	pilot oil supply internal, pilot oil drain external
		ET	pilot oil supply external, pilot oil drain external
		E	pilot oil supply external, pilot oil drain internal
6 ▶	Adjustable Stroke	AB	both side with adjustable strokes
		A	port A side with adjustable stroke
		B	port B side with adjustable stroke
7 ▶	Knob	none	without knob
		K	with knob

MODEL SPEC.

Model	Max. Flow (l/min)	Max. Operating Pressure (kgf/cm ²)	Max. Pilot Pressure (kgf/cm ²)	Min. Pilot Pressure (kgf/cm ²)	Max. Pressure (kgf/cm ²)		Max. Change Over Frequency (cycles/min)		Weight (kg)
					EXT. Drain	INT. Drain	AC	DC	
DHG-04	300	315	250	8	210	140	120	120	6.1
DHG-06	500	315	250	8	210	140	120	120	12.0

Three Positions		Two Positions			
DHG-3C2		DHG-2B2A		DHG-2B2B	
DHG-3C3		DHG-2B3A		DHG-2B3B	
DHG-3C4		DHG-2B4A		DHG-2B4B	
DHG-3C40		DHG-2B40A		DHG-2B40B	
DHG-3C5		DHG-2B5A		DHG-2B5B	
DHG-3C60		DHG-2B60A		DHG-2B60B	
DHG-3C7		DHG-2B7A		DHG-2B7B	
DHG-3C9		DHG-2B9A		DHG-2B9B	
DHG-3C10		DHG-2B10A		DHG-2B10B	
DHG-3C11		DHG-2B11A		DHG-2B11B	
DHG-3C12		DHG-2B12A		DHG-2B12B	

DIMENSION

(UNIT : mm)

► DHG-04-AB-K

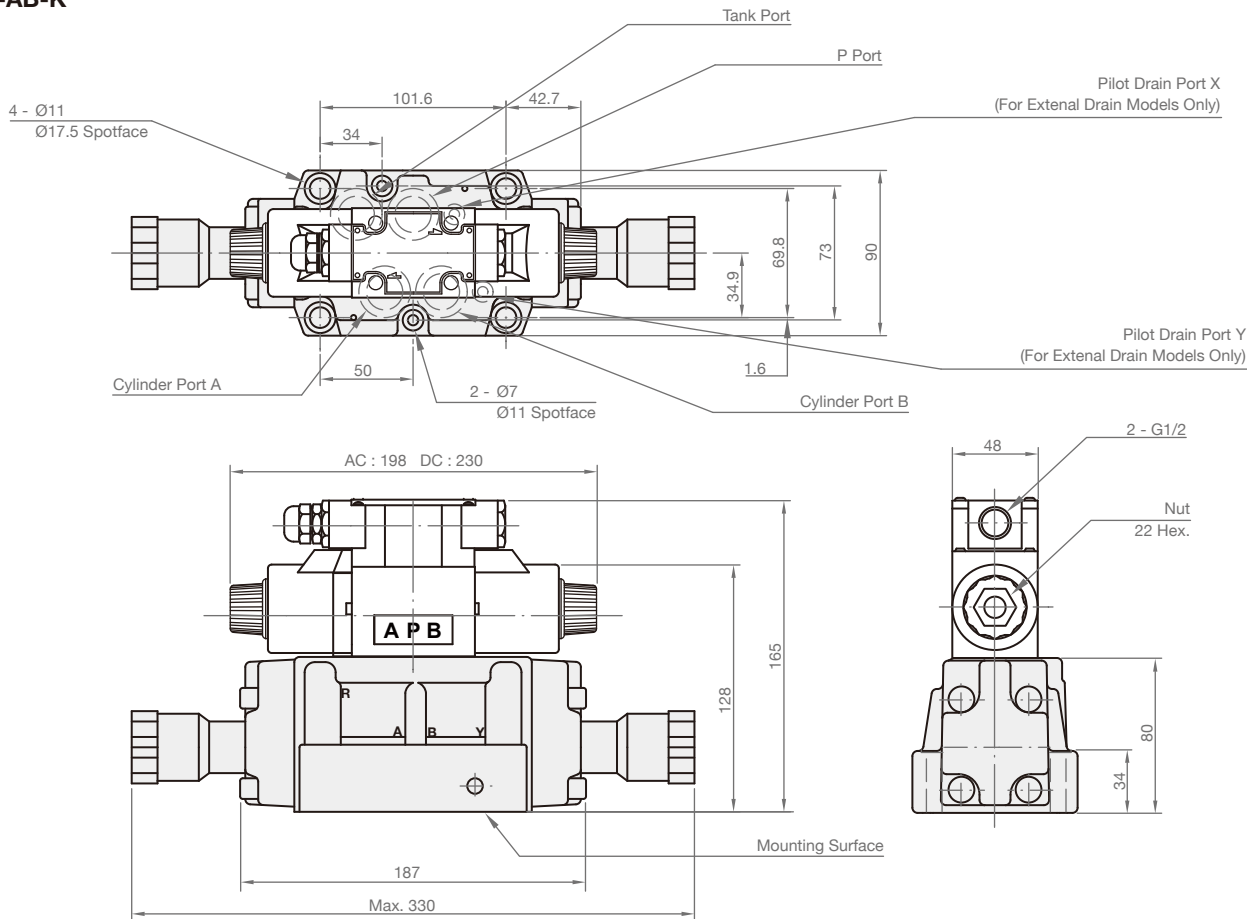

► DHG-04

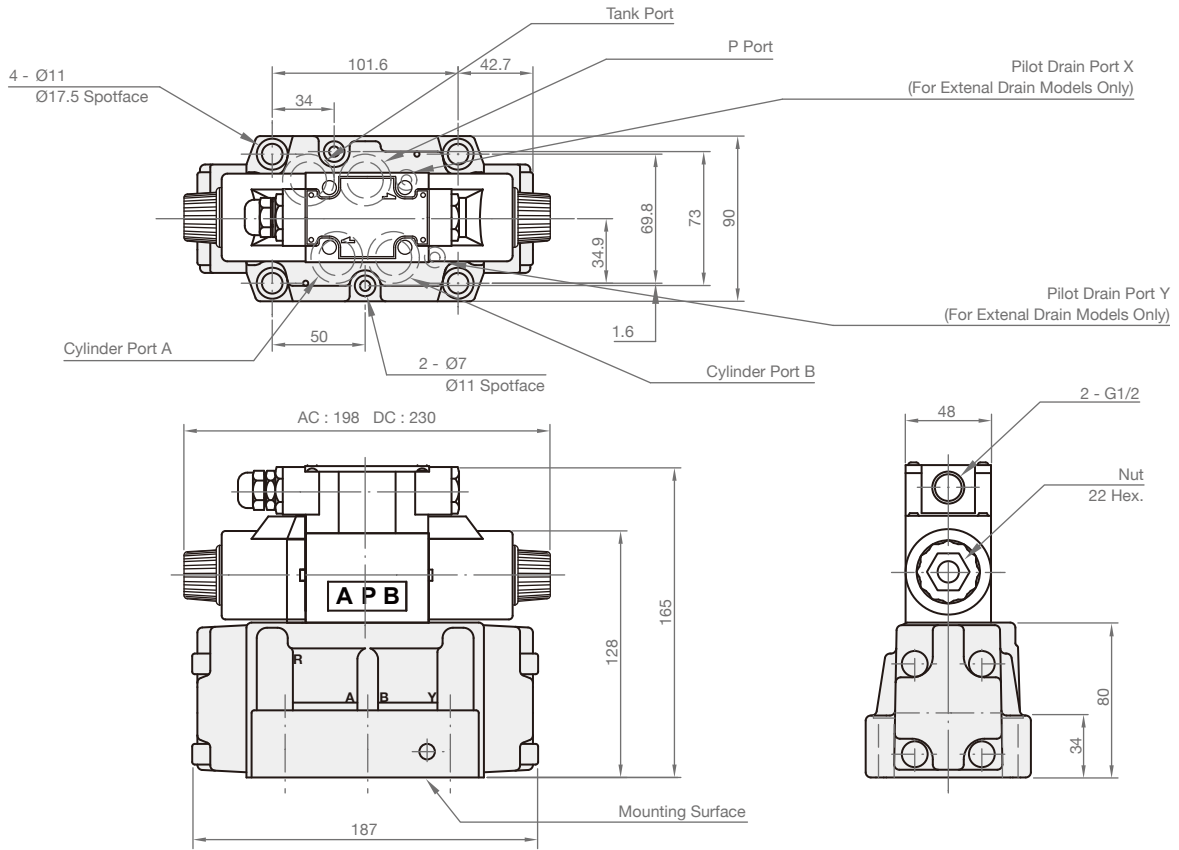

► DHG-06-AB-K

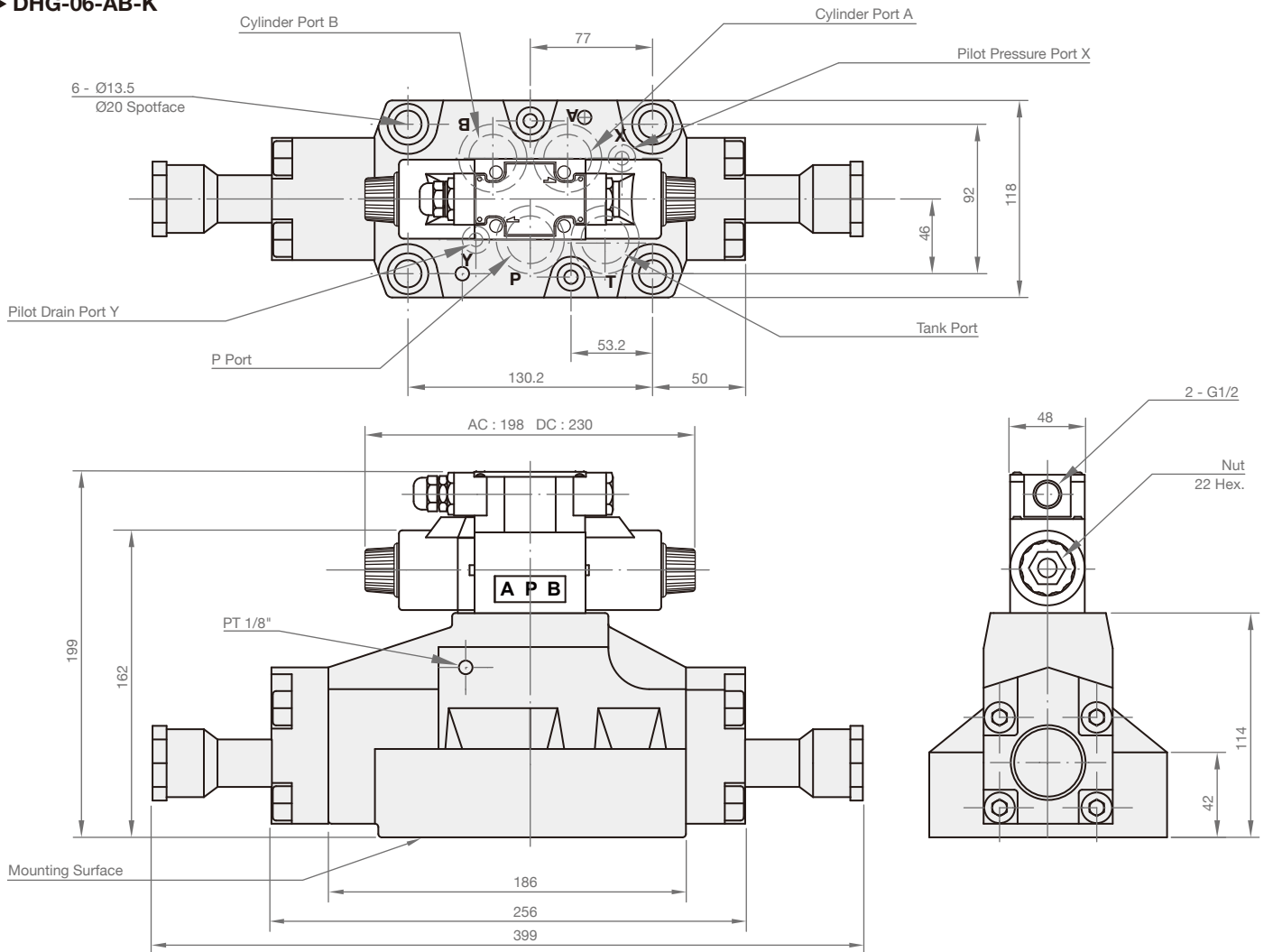

► DHG-06

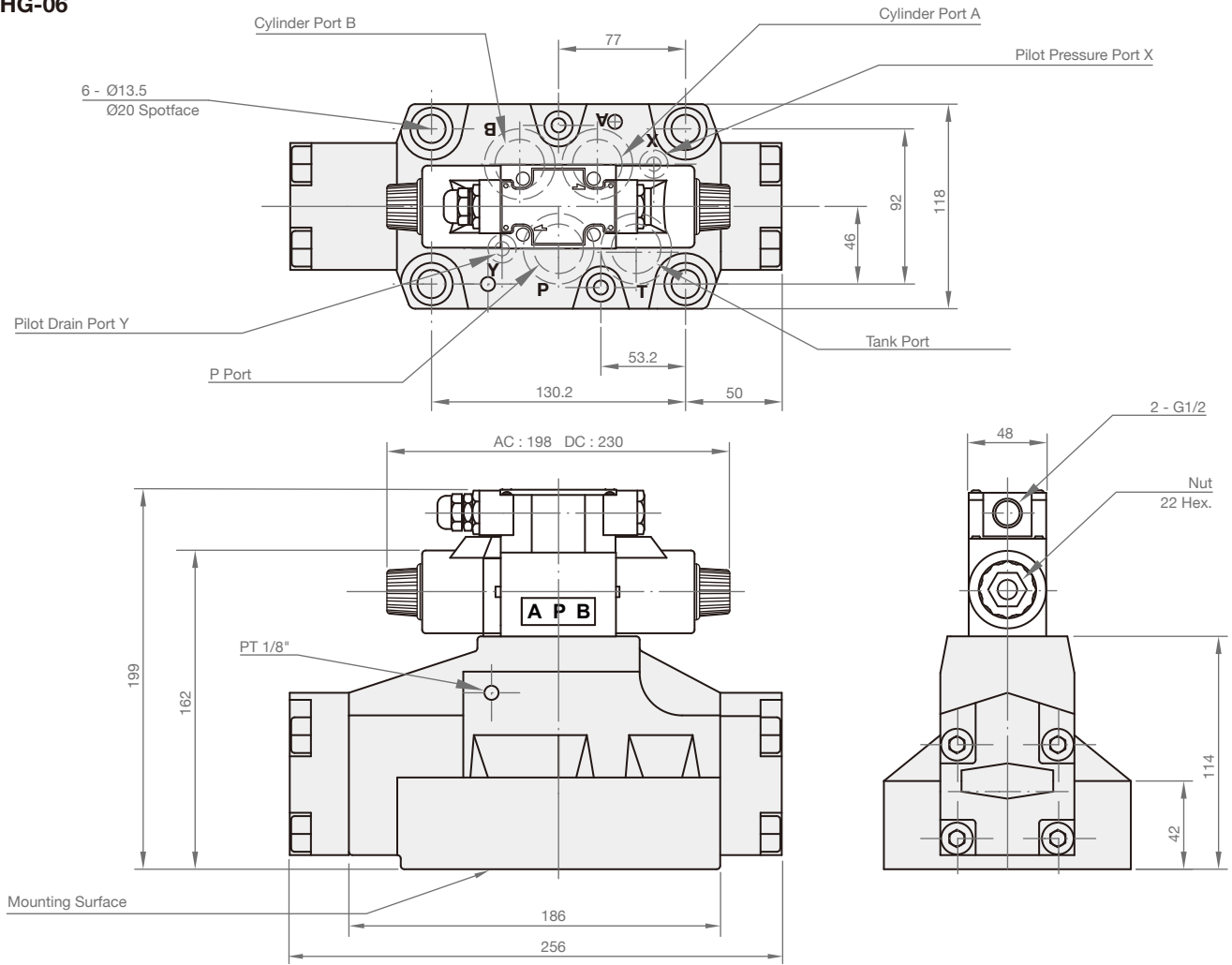

Steed Machinery Co., Ltd.

No. 28, Ruiguang St., South Dist.,
Taichung City 402006,
Taiwan
Tel : +886-4-2285-4867
Fax : +886-4-2285-2848
Email : info@steedmachinery.com.tw

more information
www.steedmachinery.com.tw

