

INTRODUCTION

“POLARIS” more than fifty years of Casappa experience in design and production of hydraulic components, characterized by large investments in research and development in order to propose new and personalized solutions to the market.

Our use of CAD 3D in the development of this generation permit us the 3D modelling and the virtual simulation of the behaviour of the components inserted in the hydraulic circuit. This means that the process will take less time and the quality of the products is better.

Polaris pumps and motors are basically composed of a gear housing in aluminium alloy, two gear wheels supported by sleeve bearings and two end plates, the front and the rear cover, either in aluminium or in cast iron with excellent mechanical characteristics.

Our success is based largely on the quality of our product. This guaranties the consistencies of the efficiencies and low level of noise emission during the life of our products.

DISPLACEMENTS

From 1,07 cm³/rev (0.07 in³/rev)

To 91,10 cm³/rev (5.56 in³/rev)

PRESSURE

Max. constant operating pressure 260 bar (3770 psi)

Max. system pressure (relief valve setting) 280 bar (4060 psi)

Max. peak of pressure 300 bar (4350 psi)

SPEED

Max. 4000 min⁻¹

- Available in groups 10, 20 and 30.
- Drive shafts, mounting flanges and ports according to the international standards.
- Combination of multiple pumps in standard version, common inlet and separated stages.
- Integrated outboard bearings for heavy duty application.
- Many types of built-in valves.

TYPICAL APPLICATIONS

- Building & Construction
- Material Handling
- Agriculture
- Forestry
- Turf care & Mowers
- Fan Drive

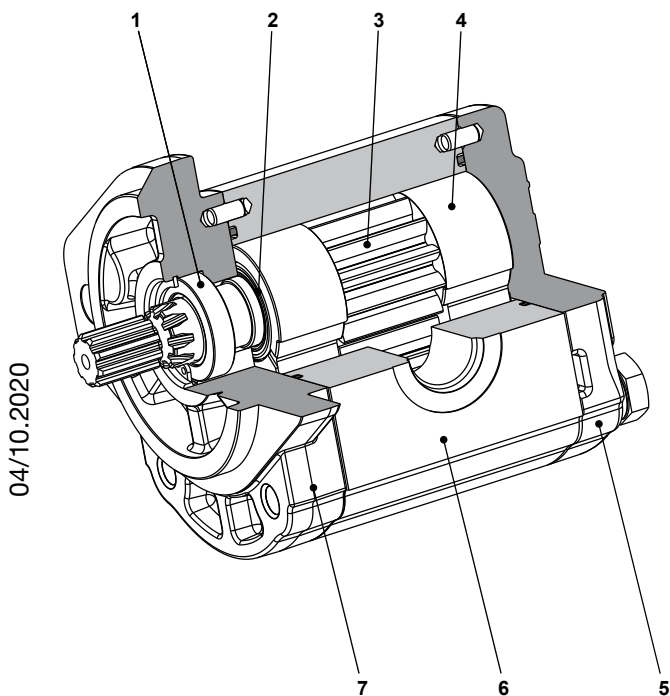

1	Shaft seal
2	Seal
3	Gear
4	Thrust plate
5	Rear cover
6	Body
7	Mounting flange

INSTRUCTIONS

INSTALLATION

Pump

The direction of rotation of single-rotation pumps must be the same as that of the drive shaft. Check that the coupling flange correctly aligns the transmission shaft and the pump shaft. Flexible couplings should be used (never rigid fittings) which will not generate an axial or radial load on the pump shaft.

Motor

The direction of rotation of single-rotation motors must match circuit connections. Check that the coupling flange correctly aligns the transmission shaft and the motor shaft. Flexible couplings should be used (never rigid fittings) which will not generate an axial or radial load on the motor shaft.

TANK

Tank capacity must be sufficient for the system's operating conditions (~ 3 times the amount of oil in circulation) to avoid overheating of the fluid. A heat exchanger should be installed if necessary. The intake and return lines in the tank must be spaced apart (by inserting a vertical divider) to prevent the return-line oil from being taken up again immediately.

LINES

The lines must have a major diameter which is at least as large as the diameter of pump or motor ports, and must be perfectly sealed. To reduce loss of power, the lines should be as short as possible, reducing the sources of hydraulic resistance (elbow, throttling, gate valves, etc.) to a minimum. A length of flexible tubing is recommended to reduce the transmission of vibrations. All return lines must end below the minimum oil level, to prevent foaming. Before connecting the lines, remove any plugs and make sure that the lines are perfectly clean.

HYDRAULIC FLUID

Use hydraulic fluid conforming to viscosity data as specified in the first pages of the catalogue. Avoid using mixtures of different oils which could result in decomposition and reduction of the oil's lubricating power.

FILTERS

We recommend filtering the entire system flow. Filters on suction and return line must be fitted in according to the contamination class as indicated in the first pages of the catalogue. Casappa recommends to use its own production filters:

STORAGE

The storage must be in a dry environment.

Max storage time in ideal conditions is 24 months.

The ideal storage temperature is between 5 °C (41 °F) and 20 °C (68 °F). No problem in case of temperature between -40 °C (-40 °F) and 50 °C (122 °F). Below -40 °C (-40 °F) please consult our pre-sales department.

STARTING UP

Check that all circuit connections are tight and that the entire system is completely clean. Insert the oil in the tank, using a filter. Bleed the circuit to assist in filling. Set the pressure relief valves to the lowest possible setting. Turn on the system for a few moments at minimum speed, then bleed the circuit again and check the level of oil in the tank.

If the difference between pump or motor temperature and fluid temperature exceeds 10 °C (18 °F), rapidly switch the system on and off to heat it up gradually. Then gradually increase the pressure and speed of rotation until the pre-set operating levels as specified in the catalogue are attained.

COLD START

Cold start is meant short term and low idle. During cold start of the machine the following limits can be applied:

Minimum inlet pressure	0,5 bar abs. (7 psi)
Outlet pressure (pumps) Inlet pressure (motors)	≤ 50 bar (725 psi)
Max drain pressure / Max back pressure for single rotation motors	+ 50% of standard values
Speed	≤ 1500 min ⁻¹
Minimum temperature	-40 °C (-40 °F)
Max oil viscosity	2000 mm ² /s (cSt) [9100 SSU]

If the ambient temperature is lower than -20 °C (-4 °F) the system speed and pressure must be limited until the hydraulic oil temperature exceeds -20 °C (-4 °F).

PERIODICAL CHECKS - MAINTENANCE

Keep the outside surface clean especially in the area of the drive shaft seal. In fact, abrasive powder can accelerate wear on the seal and cause leakage. Replace filters regularly to keep the fluid clean. The oil level must be checked and oil replaced periodically depending on the system's operating conditions.



FEATURES

Replaces: 05/04.2023



Construction	External gear pumps and motors 3-piece construction
Mounting	EUROPEAN - SAE - GERMAN standard flanges
Ports	Threaded or flanged
Direction of rotation (looking on drive shaft)	Anti-clockwise (S) - clockwise (D) - reversible external drain (R - L) reversible internal drain (B)
Inlet pressure range for pumps	0,7 ÷ 3 bar abs. (10 ÷ 44 psi) If p > 1,5 bar abs. (22 psi) specific shaft sealing have to be applied. Please consult our pre-sales department.
Max back pressure for single rotation motors	5 bar (73 psi) continuous @ min. speed 350 min ⁻¹ 1 bar (14.5 psi) continuous @ max. speed (see page 7)
Max drain line pressure on reversible rotation motors	5 bar (73 psi) continuous @ min. speed 350 min ⁻¹ 1 bar (14.5 psi) continuous @ max. speed (see page 7)
Max back pressure on in series motors	150 bar (2175 psi)
Fluid temperature range	See table (1)
Fluid	Mineral oil based hydraulic fluids to ISO/DIN. Please contact us for other fluids
Viscosity range	From 12 to 100 mm ² /s (cSt) [60 to 456 SSU] recommended Up to 750 mm ² /s (cSt) [3410 SSU] permitted
Filtering requirement and recommended fluid contamination	See table (2) page 6

Tab. 1

Type	Fluid composition	Max pressure bar (psi)	Max speed min ⁻¹	Temperature - °C (°F)			Seals (●)	Shaft seals option (◆)
				Min	Max continuous	Max peak		
ISO/DIN	Mineral oil based hydraulic fluid to ISO/DIN	See page 7	See page 7	-25 (-13)	80 (176)	100 (212)	N	D C1
				-25 (-13)	110 (230)	125 (257)	V	
				-25 (-13)	110 (230)	125 (257)	T-PV	

(●) **N** = Buna NBR (standard) - **V** = Viton-FKM - **T-PV** = Hydrogenated buna HNBR seals with Viton-FKM shaft seals (only for PLP20)

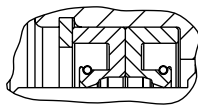
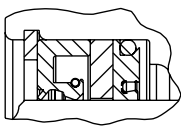
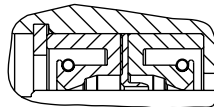
06/02.2024

	D (◆) shaft seals with wiper seal	C1 (◆) High pressure special shaft seal
Single rotation pumps Max drain line pressure: 0,5 bar (7 psi)		
Single rotation motors Reversible rotation pumps and motors Max drain line pressure: 5 bar (73 psi) @ 350 min ⁻¹		Max drain line pressure: 10 bar (145 psi) @ 2000 min ⁻¹ 

FEATURES

Filtration

Casappa recommends to use its own production filters:



Tab. 2

Working pressure bar (psi)	$\Delta p < 140$ (2030)	$140 < \Delta p < 210$ (2030) (3045)	$\Delta p > 210$ (3045)
Contamination class NAS 1638	10	9	8
Contamination class ISO 4406	21/19/16	20/18/15	19/17/14
Achieved with filter $\beta_{10}(c) \geq 75$ according to ISO 16889	-	10 μm	10 μm
Achieved with filter $\beta_{25}(c) \geq 200$ according to ISO 16889	25 μm	-	-

DEFINITION OF ROTATION DIRECTION LOOKING AT THE DRIVE SHAFT

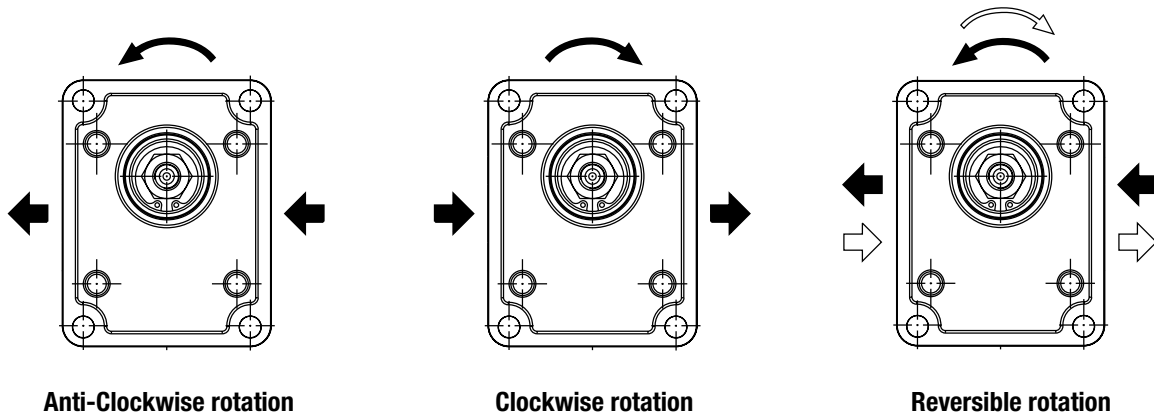

GENERAL NOTES

Available with different inlet and outlet ports.
Please contact us for more information.

PRESSURE DEFINITION

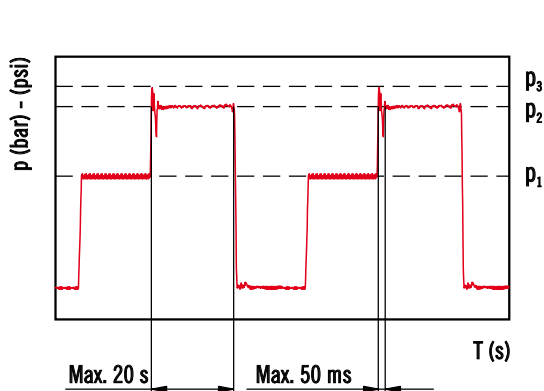

- p_1 Constant operating pressure
- p_2 System pressure (relief valve setting)
- p_3 Peak of pressure

The peak of pressure is the max pressure allowed and it corresponds to the overshoot of the relief valve.

Please note that both relief valve setting and overshoot must be lower than their limits.
If the relief setting is compliant but the overshoot is higher than the limit, the relief setting must be decreased until the overshoot is compliant to Casappa limit.

Please contact us for high frequency applications.

04/10.2020

FEATURES

Series	Pump type PLP Motor type PLM	Displacement cm ³ /rev (in ³ /rev)	Max. pressure			Max. speed	Min. speed min ⁻¹
			P ₁	P ₂	P ₃		
			bar (psi)				
POLARIS 10	PL. 10•1	1,07 (0.07)	260 (3770)	280 (4060)	290 (4205)	4000	650
	PL. 10•1,5	1,60 (0.10)	260 (3770)	280 (4060)	290 (4205)	4000	650
	PL. 10•2	2,13 (0.13)	260 (3770)	280 (4060)	290 (4205)	4000	650
	PL. 10•2,5	2,67 (0.16)	260 (3770)	280 (4060)	290 (4205)	4000	650
	PL. 10•3,15	3,34 (0.20)	260 (3770)	280 (4060)	290 (4205)	4000	650
	PL. 10•4	4,27 (0.26)	250 (3625)	270 (3915)	280 (4060)	4000	650
	PL. 10•5	5,34 (0.33)	250 (3625)	270 (3915)	280 (4060)	4000	650
	PL. 10•5,8	6,20 (0.38)	230 (3335)	250 (3625)	260 (3770)	3500	650
	PL. 10•6,3	6,67 (0.41)	230 (3335)	250 (3625)	260 (3770)	3500	650
	PL. 10•8	8,51 (0.52)	180 (2610)	200 (2900)	210 (3045)	3500	650
PL. 10•10	10,67 (0.65)	140 (2030)	160 (2320)	170 (2465)	3500	650	
POLARIS 20	PL. 20•4	4,95 (0.30)	250 (3625)	280 (4060)	300 (4350)	4000	600
	PL. 20•6,3	6,61 (0.40)	250 (3625)	280 (4060)	300 (4350)	4000	600
	PL. 20•7,2	7,29 (0,44)	250 (3625)	280 (4060)	300 (4350)	4000	600
	PL. 20•8	8,26 (0.50)	250 (3625)	280 (4060)	300 (4350)	3500	600
	PL. 20•9	9,17 (0.56)	250 (3625)	280 (4060)	300 (4350)	3500	600
	PL. 20•10,5	10,9 (0.66)	250 (3625)	280 (4060)	300 (4350)	3500	600
	PL. 20•11,2	11,23 (0.69)	250 (3625)	280 (4060)	300 (4350)	3500	600
	PL. 20•14	14,53 (0.89)	250 (3625)	280 (4060)	300 (4350)	3500	500
	PL. 20•16	16,85 (1.03)	250 (3625)	280 (4060)	300 (4350)	3000	500
	PL. 20•19	19,09 (1.16)	200 (2900)	220 (3190)	240 (3480)	3000	500
	PL. 20•20	21,14 (1.29)	200 (2900)	220 (3190)	240 (3480)	3000	500
	PL. 20•24,5	24,84 (1.52)	170 (2465)	190 (2755)	210 (3045)	2500	500
	PL. 20•25	26,42 (1.61)	170 (2465)	190 (2755)	210 (3045)	2500	500
	PL. 20•27,8	28,21 (1.72)	130 (1885)	150 (2175)	170 (2465)	2000	500
PL. 20•31,5	33,03 (2.01)	130 (1885)	150 (2175)	170 (2465)	2000	500	
POLARIS 30	PL. 30•22	21,99 (1.34)	250 (3625)	270 (3915)	280 (4060)	3000	350
	PL. 30•27	26,70 (1.63)	250 (3625)	270 (3915)	280 (4060)	3000	350
	PL. 30•34	34,55 (2.11)	240 (3480)	260 (3770)	270 (3915)	3000	350
	PL. 30•38	39,27 (2.40)	240 (3480)	260 (3770)	270 (3915)	3000	350
	PL. 30•43	43,98 (2.68)	230 (3335)	250 (3625)	260 (3770)	3000	350
	PL. 30•51	51,83 (3.16)	210 (3045)	230 (3335)	240 (3480)	2500	350
	PL. 30•61	61,26 (3.74)	190 (2755)	210 (3045)	220 (3190)	2500	350
	PL. 30•73	73,82 (4.50)	170 (2465)	190 (2755)	200 (2900)	2500	350
	PL. 30•82	81,68 (4.98)	160 (2320)	170 (2465)	180 (2610)	2200	350
	PL. 30•90	91,10 (5.56)	150 (2175)	160 (2320)	170 (2465)	2200	350

04/10.2020

Pressure values in the table refer to side ports unidirectional pumps and motors.
 For reversible pumps and motors, max pressures are 250 bar (3600 psi) excepted those with lower pressure values.
 Please contact us for different working conditions.

PLM 20

POLARIS 20 GEAR MOTORS PERFORMANCE CURVES

PLM 20

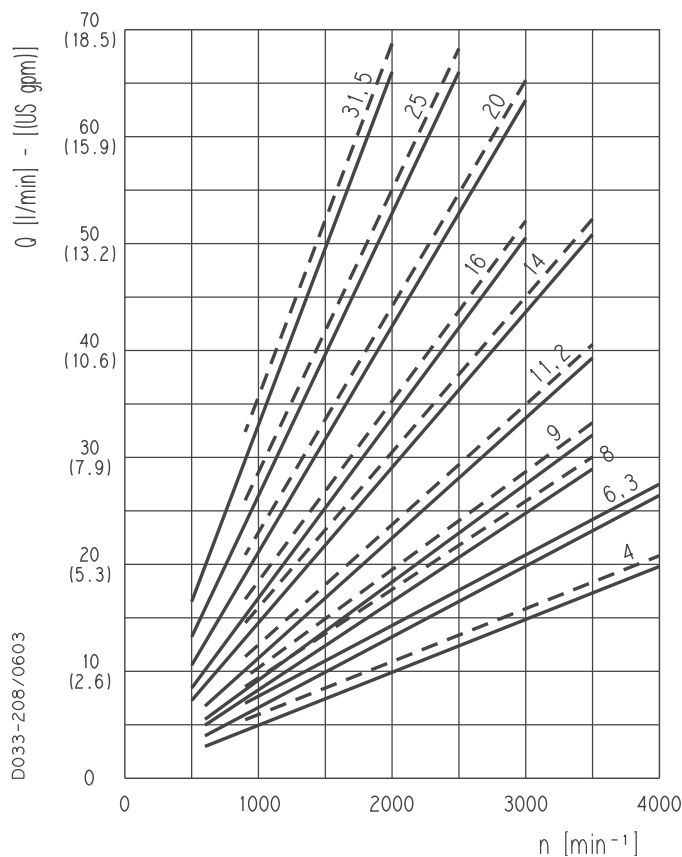

Each curve has been obtained at 50 °C (122 °F), using oil with viscosity 46 cSt (210 SSU) at 40 °C (104 °F) and at these pressures.

PLM 20•4	—	20 bar (290 psi)
	- - -	250 bar (3625 psi)
PLM 20•6,3	—	20 bar (290 psi)
	- - -	250 bar (3625 psi)
PLM 20•8	—	20 bar (290 psi)
	- - -	250 bar (3625 psi)
PLM 20•9	—	20 bar (290 psi)
	- - -	250 bar (3625 psi)
PLM 20•11,2	—	20 bar (290 psi)
	- - -	250 bar (3625 psi)
PLM 20•14	—	20 bar (290 psi)
	- - -	250 bar (3625 psi)
PLM 20•16	—	20 bar (290 psi)
	- - -	250 bar (3625 psi)
PLM 20•20	—	20 bar (290 psi)
	- - -	200 bar (2900 psi)
PLM 20•25	—	20 bar (290 psi)
	- - -	170 bar (2465 psi)
PLM 20•31,5	—	20 bar (290 psi)
	- - -	130 bar (1885 psi)
PLM 20•7,2	—	20 bar (290 psi)
	- - -	250 bar (3625 psi)
PLM 20•10,5	—	20 bar (290 psi)
	- - -	250 bar (3625 psi)
PLM 20•19	—	20 bar (290 psi)
	- - -	200 bar (2900 psi)
PLM 20•24,5	—	20 bar (290 psi)
	- - -	270 bar (2465 psi)
PLM 20•27,8	—	20 bar (290 psi)
	- - -	130 bar (1885 psi)

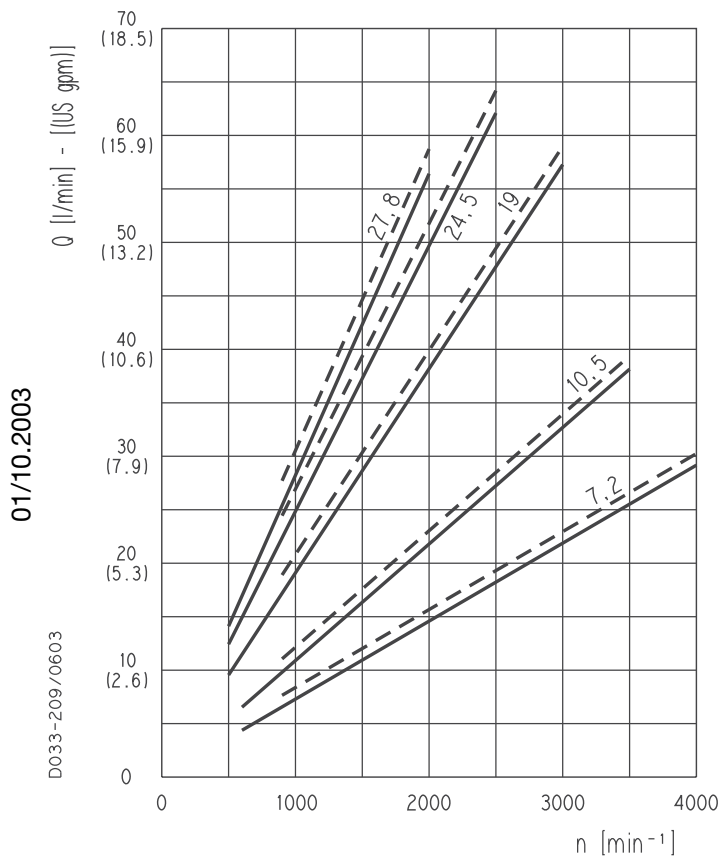

01/10.2003

PLM 20

POLARIS 20 GEAR MOTORS PERFORMANCE CURVES

PLM 20•25

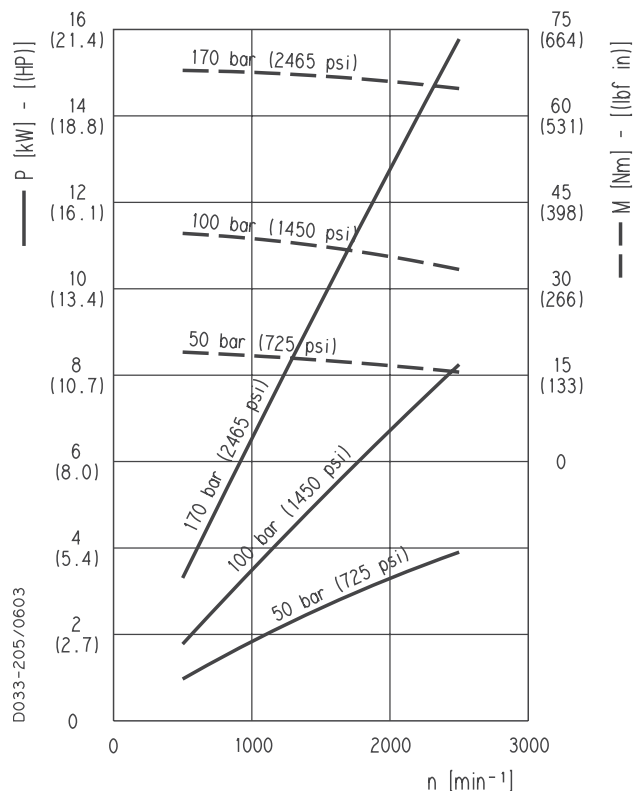

PLM 20•27,8

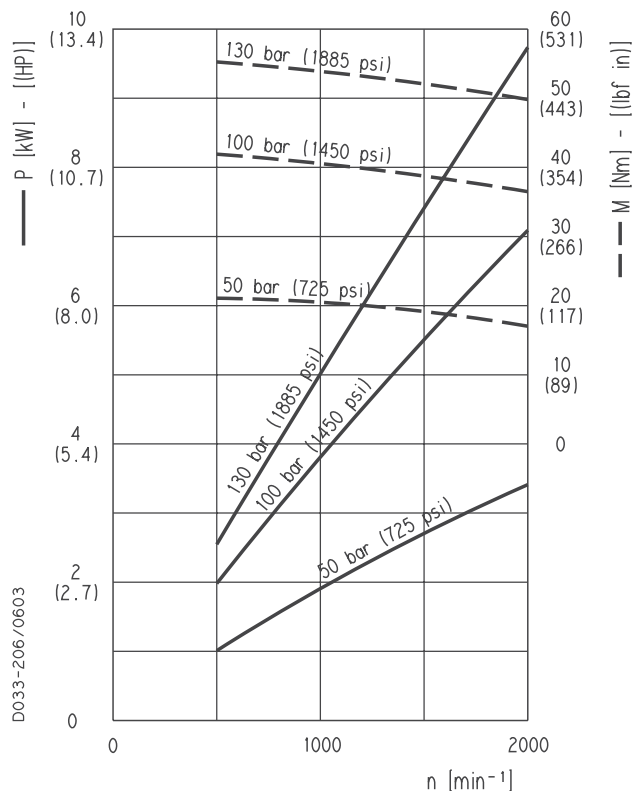

PLM 20•31,5

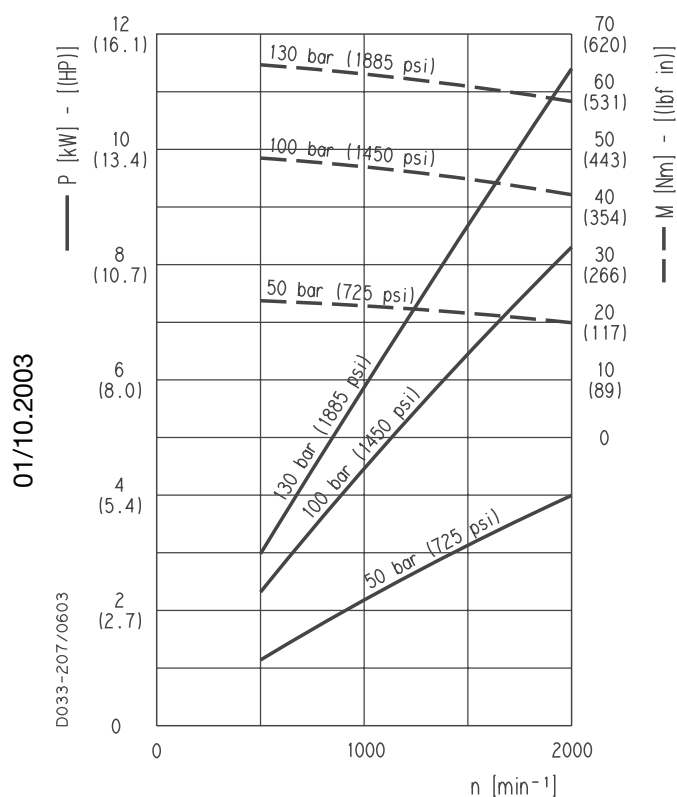

01/10.2003

POLARIS 20

SINGLE UNITS DIMENSIONS - SIDE PORTS

L

Drive shafts: page 53 ÷ 55
Mounting flange: for X dimension see page 61 ÷ 66

Ports availability: European, Split, Gas, SAE German. See page 70

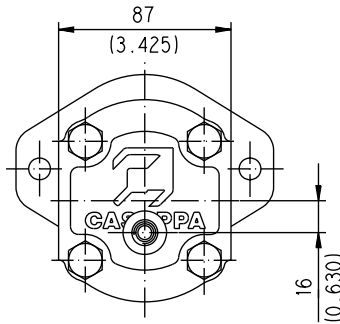

Reversible R

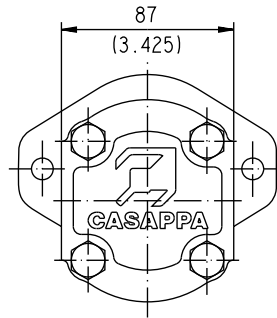

Single rotation S - D and Reversible B

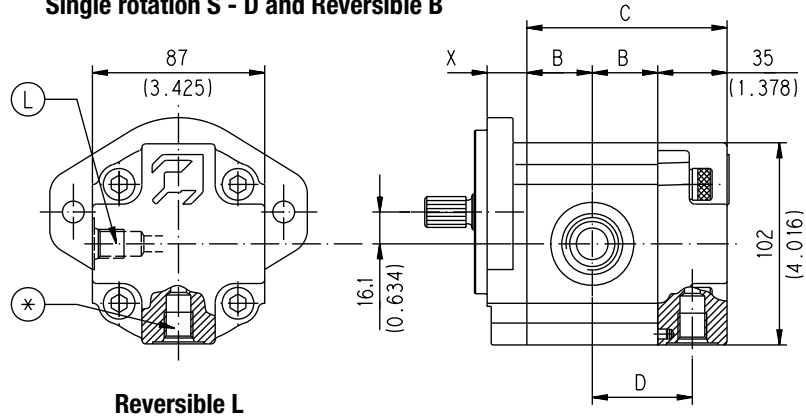
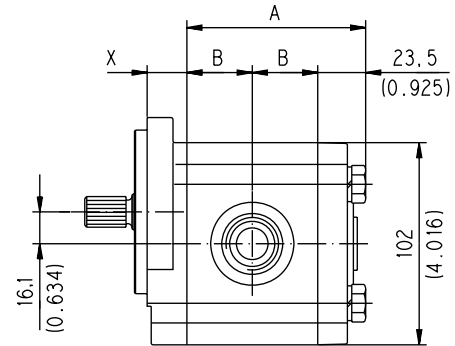

Reversible L

For single rotation S - D and reversible B and R the rear cover is available in cast iron and aluminium.
For reversible rotation L the rear cover is in aluminium only.

Reversible L drain port position:

- L = Side
- * = Bottom

Pump type Motor type	A	B	C	D
	mm (in)	mm (in)	mm (in)	mm (in)
PL. 20•4	75 (2.9528)	25,75 (1.0138)	86,5 (3.4055)	43,25 (1.7028)
PL. 20•6,3	77,5 (3.0512)	27 (1.0630)	89 (3.5039)	44,5 (1.7520)
PL. 20•7,2	78,5 (3.0917)	27,5 (1.083)	90 (3.5445)	45 (1.7722)
PL. 20•8	80 (3.1496)	28,25 (1.1122)	91,5 (3.6024)	45,75 (1.8012)
PL. 20•9	81,3 (3.2008)	28,9 (1.1378)	92,8 (3.6535)	46,4 (1.8268)
PL. 20•10,5	84 (3.3070)	30,25 (1.1909)	95,5 (3.7598)	47,75 (1.8799)
PL. 20•11,2	84,5 (3.3268)	30,5 (1.2008)	96 (3.7795)	48 (1.8898)
PL. 20•14	89,5 (3.5236)	33 (1.2992)	101 (3.9764)	50,5 (1.9882)
PL. 20•16	93 (3.6614)	34,75 (1.3681)	104,5 (4.1142)	52,25 (2.0571)
PL. 20•19	96,4 (3.7952)	36,45 (1.4350)	107,9 (4.2480)	53,9 (2.12)
PL. 20•20	99,5 (3.9173)	38 (1.4961)	111 (4.3701)	55,5 (2.1850)
PL. 20•24,5	105,1 (4.1378)	40,8 (1.6063)	116,6 (4.5905)	58,3 (2.2953)
PL. 20•25	107,5 (4.2323)	42 (1.6535)	119 (4.6850)	59,5 (2.3425)
PL. 20•27,8	110,2 (4.3386)	43,35 (1.7067)	121,7 (4.7913)	60,85 (2.3957)
PL. 20•31,5	117,5 (4.6260)	47 (1.8504)	129 (5.0787)	64,5 (2.5394)

04/10.2020

D033-115/0603

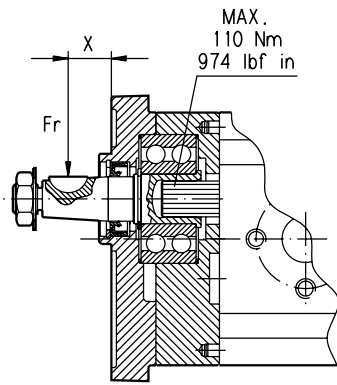

X = Distance of the radial load result from the mounting flange [mm (in)].

Each curve has been obtained at:

- Lubricant oil ISO VG 46
- Temperature 60 °C (140 °F)
- Without axial load
- Contamination level according ISO 281: $\beta_{12}(C) = 200$
- Reliability level of the calculation 90%

Example

Fr Radial load	850 N (191.3 lbf)
X	20 mm (0.79 in)
Speed	2000 min ⁻¹
Rated fatigue life	≈ 2100 h

Values shown in the diagrams are indicative only.
Please contact us for more information.

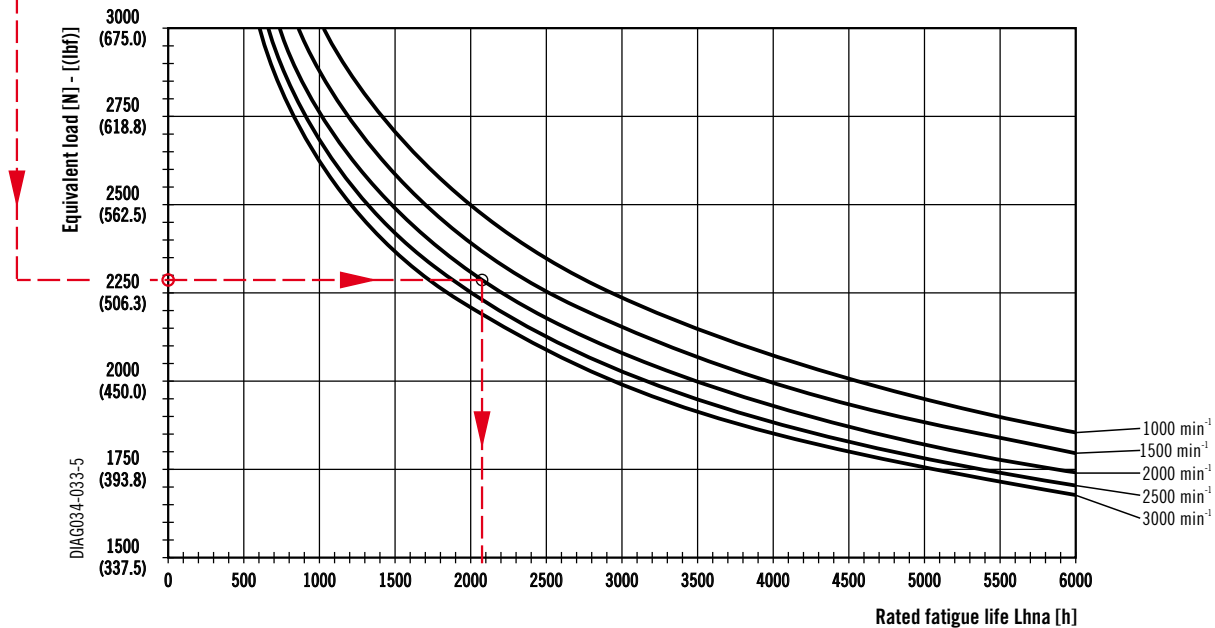
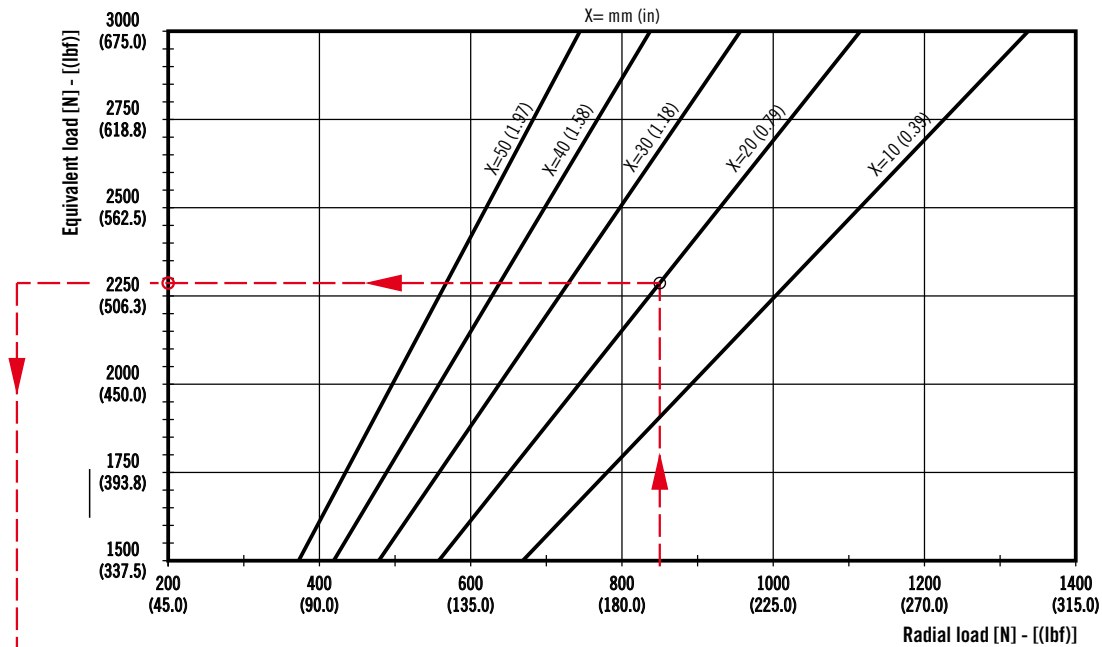

04/10.2020

POLARIS 20

DRIVE SHAFTS

SAE SPLINE

07

Mounting face refer to flange code **S1**

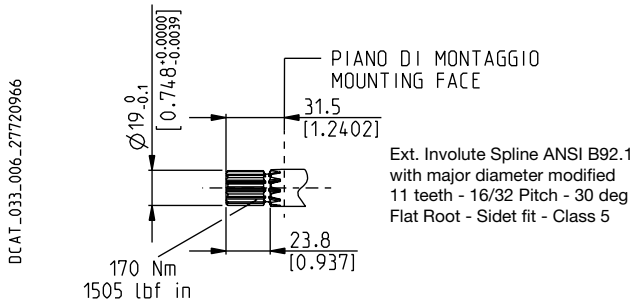

SAE "A" STRAIGHT

31

Not available with size:

20•24,5 20•27,8

Mounting face refer to flange code **S1**

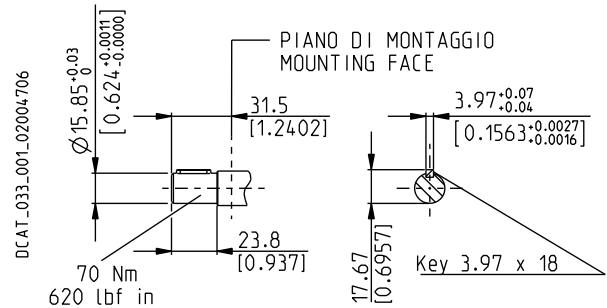

STRAIGHT

49

Not available with size:

20•19 20•24,5

Mounting face refer to flange code **S1**

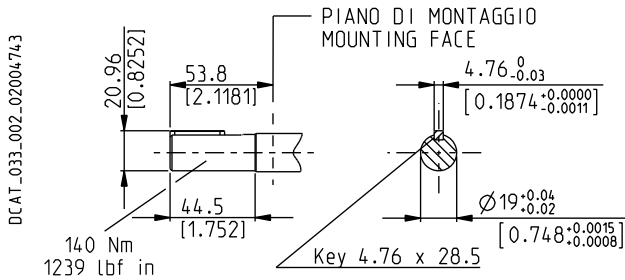

STRAIGHT

50

Mounting face refer to flange code **S1**

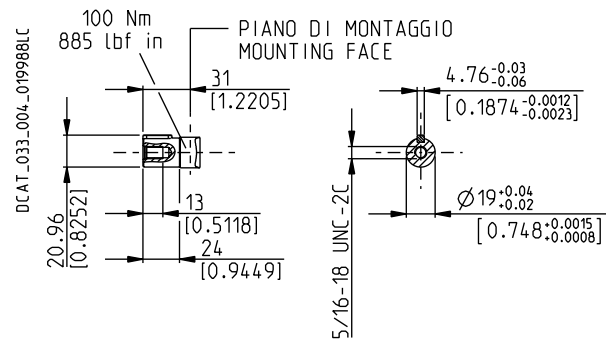

SAE "B" SPLINE

04

Mounting face refer to flange code **S5**

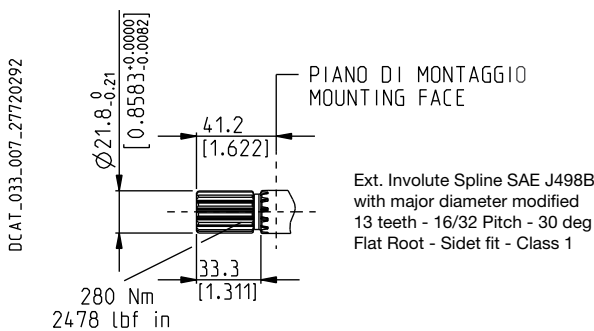

SAE "B" STRAIGHT

32

Not available with size:

20•24,5

Mounting face refer to flange code **S5**

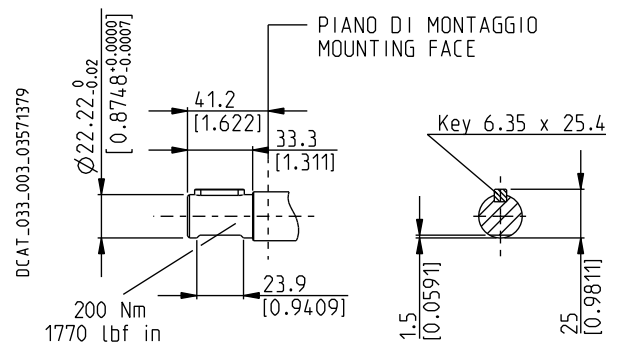

04/10.2020

POLARIS 20

MOUNTING FLANGES AND TABLE OF COMPATIBILITY

SAE "A" 2 BOLTS

S1

Material: cast iron and aluminium

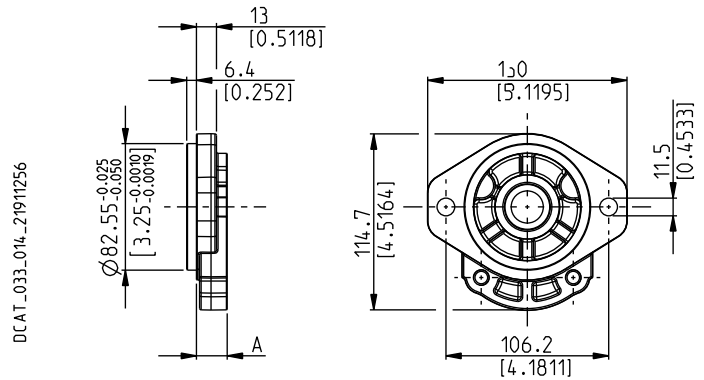

DRIVE SHAFTS

See page 53 ÷ 55

VERSIONS See page 48	A mm (in)	01	03	04	07	12	31	32	46	49	50	54	82
0	20 (0.787)	#	#	X	#	X	#	X	X	#	X	X	X
5	45,6 (1.7953)		X							X	X	X	X

Standard combination

X Available combination

SAE "A" 2 BOLTS

S2

Material: cast iron and aluminium

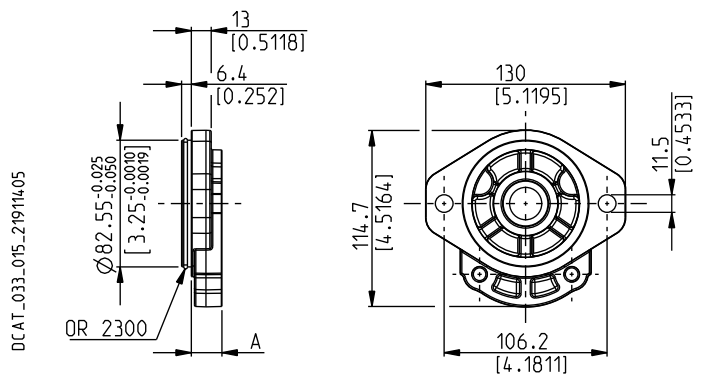

DRIVE SHAFTS

See page 53 ÷ 55

VERSIONS See page 48	A mm (in)	01	03	04	07	12	31	32	46	49	50	54	82
0	20 (0.7874)	#	#	X	#	X	#	X	X	#	X	X	X
5	45,6 (1.7953)		X							X	X	X	X

Standard combination

X Available combination

02/07.2006

PORTS SIZE



Tightening torque for low pressure side port.



Tightening torque for high pressure side port.



For reversible rotation, please consult only the tightening torque for high pressure side port.

GAS STRAIGHT THREAD PORTS

BSPP

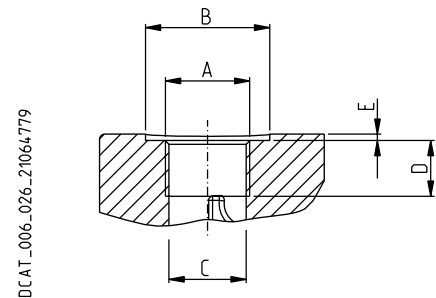
British standard pipe parallel (55°) conforms to UNI - ISO 228



CODE	Nominal size	A	Ø B	Ø C	D	E		
			mm (in)	mm (in)	mm (in)	mm (in)	Nm (lbf in)	Nm (lbf in)
GC	3/8"	G 3/8	30 (#) (1.1811)	15 (0.5906)	10 (#) (0.3937)	2 (#) (0.0787)	15 ⁺¹ (#) (133 ÷ 142)	—
			—	—	14 (0.5512)	—	15 ⁺¹ (133 ÷ 142)	25 ⁺¹ (221 ÷ 230)
GD	1/2"	G 1/2	—	19 (0.7480)	14 (0.5512)	—	20 ⁺¹ (177 ÷ 186)	50 ^{+2.5} (443 ÷ 465)
			—	—	17 (◆) (0.6693)	—	—	—
GE	3/4"	G 3/4	—	24,5 (0.9646)	18 (0.7087)	—	30 ^{+2.5} (266 ÷ 288)	90 ⁺⁵ (797 ÷ 841)
GF	1"	G 1	—	30,5 (1.2008)	18 (0.7086)	—	50 ^{+2.5} (443 ÷ 465)	130 ⁺¹⁰ (1151 ÷ 1239)
GG	1" 1/4	G 1 1/4	—	39 (1.5354)	22 (0.8661)	—	60 ⁺⁵ (531 ÷ 575)	170 ⁺¹⁰ (1505 ÷ 1593)
GH	1" 1/2	G 1 1/2	—	45 (1.7716)	24 (0.9448)	—	70 ⁺⁵ (620 ÷ 664)	210 ⁺¹⁵ (1859 ÷ 1992)

(#) = Drain port

(◆) For POLARIS 20

02/07.2006

HOW TO ORDER POLARIS 20 SINGLE UNITS

1	2	3	4	5	6	7	8	9	10	11	12	13							
PLP 20-4	L	0	-	82	E2	-	L	EA/EA	-	N	-	EL	-	C	-	*	GB	-	FS

1	Type	Pump type	Motor type
	4,95 cm ³ /rev (0.30 in ³ /rev)	PLP 20-4	PLM 20-4
	6,61 cm ³ /rev (0.40 in ³ /rev)	PLP 20-6,3	PLM 20-6,3
	7,29 cm ³ /rev (0.44 in ³ /rev)	PLP 20-7,2	PLM 20-7,2
	8,26 cm ³ /rev 0.50 in ³ /rev)	PLP 20-8	PLM 20-8
	9,17 cm ³ /rev 0.56 in ³ /rev)	PLP 20-9	PLM 20-9
	10,9 cm ³ /rev (0.66 in ³ /rev)	PLP 20-10,5	PLM 20-10,5
	11,23 cm ³ /rev (0.69 in ³ /rev)	PLP 20-11,2	PLM 20-11,2
	14,53 cm ³ /rev (0.89 in ³ /rev)	PLP 20-14	PLM 20-14
	16,85 cm ³ /rev (1.03 in ³ /rev)	PLP 20-16	PLM 20-16
	19,09 cm ³ /rev (1.16 in ³ /rev)	PLP 20-19	PLM 20-19
	21,14 cm ³ /rev (1.29 in ³ /rev)	PLP 20-20	PLM 20-20
	24,84 cm ³ /rev 1.52 in ³ /rev)	PLP 20-24,5	PLM 20-24,5
	26,42 cm ³ /rev (1.61 in ³ /rev)	PLP 20-25	PLM 20-25
	28,21 cm ³ /rev (1.72 in ³ /rev)	PLP 20-27,8	PLM 20-27,8
	33,03 cm ³ /rev (2.01 in ³ /rev)	PLP 20-31,5	PLM 20-31,5

2	Rotation	Code
	Left	S
	Right	D
	Reversible rear external drain	R
	Reversible side external drain	L
	Reversible internal drain	B

3	Versions - Outboard bearing options	Code
	Without outboard bearing	0
	With outboard bearing	W8
	With outboard bearing	5
	With outboard bearing	6
	With outboard bearing	7
	With outboard bearing	9

4	Drive shaft	Code
	European tapered 1:8	82
	German tapered 1:5	54
	German tapered 1:5	55
	Straight	46
	SAE "A" spline (9 teeth)	03
	SAE spline (10 teeth)	01
	SAE "A" spline (11 teeth)	07
	SAE "A" straight	31

Code	Drive shaft	4
49	Straight	
50	Straight	
04	SAE "B" spline	
32	SAE "B" straight	
12	DIN 54 82	
48	Straight (only for version 6)	
B1	Straight (for version 5 and 8)	
95	Tang	

Code	Mounting flange	5
E2	European	
B2	German	
B4	German 2 bolt	
B5	German 2 bolt	
B6	German 4 bolt	
U2	German 2 bolt	
S1	SAE "A" 2 bolt	
S2	SAE "A" 2 bolt	
S9	SAE "A" 2 bolt	
S5	SAE "B" 2 bolt	
W8	German	

Code	Ports position	6
L	Side	
P	Rear	

Code	Ports IN/OUT		7
GERMAN FLANGED PORTS			
	Side	Rear	Type
BE/BC			PLP 20 4-6,3-7,2-8-9-10,5-11,2-14-16-19-20-24,5-25-
BC/BE			PLM 20 27,8-31,5
EUROPEAN FLANGED PORTS			
	Side	Rear	Type
EA/EA			PLP 20 4-6,3-7,2-8-9-10,5-11,2
EB/EA			PLM 20 14-16-19-20-24,5-25-
EA/EB			PLM 20 27,8-31,5

04/10.2020

HOW TO ORDER POLARIS 20 SINGLE UNITS

7	Ports IN/OUT	Code
---	--------------	------

SAE FLANGED PORTS (SSM)		
-------------------------	--	--

Type	Side	Rear
4-6,3-7,2-8-9-10,5-11,2	PLP 20	MA/MA
	PLM 20	
14-16-19-20	PLP 20	MB/MA
	PLM 20	
24,5-25-27,8-31,5	PLP 20	MC/MB
	PLM 20	

SAE FLANGED PORTS (SSS)		
-------------------------	--	--

Type	Side	Rear
4-6,3-7,2-8-9-10,5-11,2	PLP 20	SA/SA
	PLM 20	
14-16-19-20	PLP 20	SB/SA
	PLM 20	
24,5-25-27,8-31,5	PLP 20	SC/SB
	PLM 20	

GAS STRAIGHT THREAD PORTS (BSPP)			
----------------------------------	--	--	--

Type	Side	Rear	
4-6,3-7,2-8-9-10,5-11,2	PLP 20	GD/GD	GD/GD
	PLM 20		
14-16-19-20-24,5-25-27,8-31,5	PLP 20	GE/GD	GE/GD
	PLM 20		

SAE STRAIGHT THREAD PORTS (ODT)			
---------------------------------	--	--	--

Type	Side	Rear	
4-6,3-7,2-8-9-10,5-11,2	PLP 20	OC/OC	OC/OC
	PLM 20		
14-16-19-20-24,5-25-27,8-31,5	PLP 20	OD/OC	OD/OC
	PLM 20		

8	Seals (a)	Code
---	-----------	------

Buna (standard)		N
Viton		V
Hydrogenated buna HNBR seals with Viton-FKM shaft seals		T-PV

9	Cover options (b)	Code
---	-------------------	------

Cast iron mounting flange and rear cover (no code)		
Aluminium mounting flange and cast iron rear cover		E
Cast iron mounting flange and aluminium rear cover		L
Aluminium mounting flange and rear cover		EL

10	Shaft seal options	Code
----	--------------------	------

Standard seal with wiper seal		D
High back pressure seal		C1

Code	Drain port position - Rev. rotation L	11
------	---------------------------------------	----

L	Side drain with side port position	
*	Side drain with bottom port position	

Code	Drain port	12
------	------------	----

IN/OUT GERMAN FLANGED PORTS		
-----------------------------	--	--

Side	Rear	Type
TA	PLP 20	4-6,3-7,2-8-9-10,5-11,2-24,5-25-27,8-31,5
	PLM 20	

IN/OUT EUROPEAN FLANGED PORTS		
-------------------------------	--	--

Side	Rear	Type
GB	PLP 20	4-6,3-7,2-8-9-10,5-11,2-24,5-25-27,8-31,5
	PLM 20	

IN/OUT SAE FLANGED PORTS (SSM)		
--------------------------------	--	--

Side	Rear	Type
GB	PLP 20	4-6,3-7,2-8-9-10,5-11,2-24,5-25-27,8-31,5
	PLM20	

IN/OUT SAE FLANGED PORTS (SSS)		
--------------------------------	--	--

Side	Rear	Type
03	PLP 20	4-6,3-7,2-8-9-10,5-11,2-24,5-25-27,8-31,5
	PLM 20	

IN/OUT GAS STRAIGHT THREAD PORTS (BSPP)		
---	--	--

Side	Rear	Type	
GB	GB	PLP 20	4-6,3-7,2-8-9-10,5-11,2-24,5-25-27,8-31,5
		PLM 20	

IN/OUT SAE STRAIGHT THREAD PORTS (ODT)		
--	--	--

Side	Rear	Type	
03	03	PLP 20	4-6,3-7,2-8-9-10,5-11,2-24,5-25-27,8-31,5
		PLM 20	

Code	Shaft arrangement	13
------	-------------------	----

FS	Female spline	
-----------	---------------	--

- (a) Choose the seals according to the temperature shown on page 4.
- (b) Mounting flange material on page 61 ÷ 66
Rear cover material on page 34 ÷ 35

04/10.2020