

# Pressure control valves type AGIR, AGIS, AGIU

two stage, subplate mounting, ISO 5781 sizes 10, 20 and 32

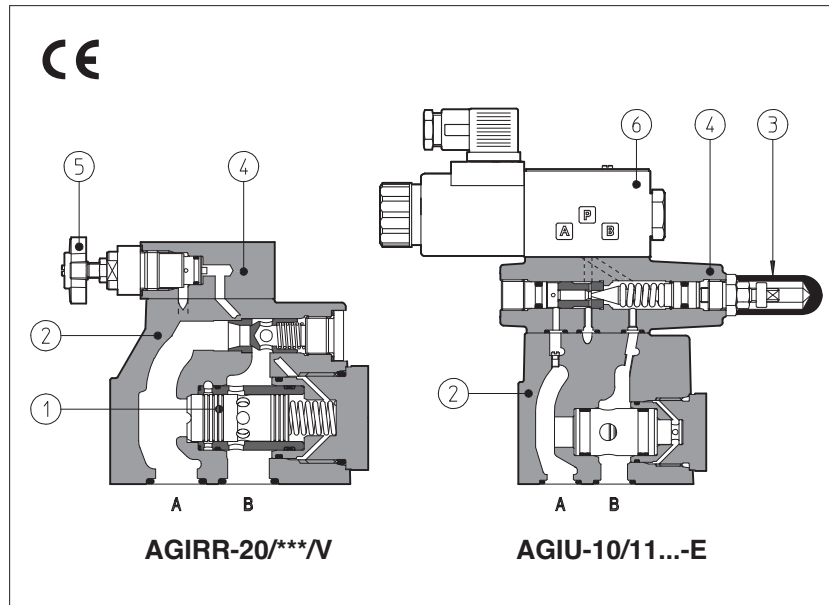

Two stage pressure control valves with balanced poppet designed to operate in oil hydraulic systems.

**AGIR:** pressure reducing;

**AGIS:** sequence;

**AGIU:** unloading.

In standard versions the piloting pressure of the poppet ① of the main stage ② is regulated by means of a grub screw protected by cap ③ in the cover ④.

Optional versions with setting adjustment by handwheel ⑤ instead of the grub screw are available on request.

Clockwise rotation increases pressure.

Unloading valves AGIU can be equipped with a venting solenoid valve ⑥ type:

- DHE for AC and DC supply, high performances with **cURus** certified solenoids
- DHL for AC and DC supply, compact execution

Mounting surface: **ISO 5781 size 10, 20 and 32**

Max flow:

**AGIR = 160, 300, 400 l/min**

**AGIS = 200, 400, 600 l/min**

**AGIU = 100, 200, 300 l/min**

Pressure up to **350 bar**

## 1 MODEL CODE

<b>AGIU</b>	*	-	20	/	10	/	210	/	V	-	E	X	24DC	**	/	*	
Pressure control valves subplate mounting <b>AGIR</b> = pressure reducing <b>AGIS</b> = sequence <b>AGIU</b> = unloading  Only for AGIR and AGIS: <b>R</b> = with check valve - = without check valve																	Seals material, see section ⑥: - = NBR <b>PE</b> = FKM <b>BT</b> = HNBR (3)
Size: <b>10 20 32</b>																	Series number
Optional solenoid valve for venting (1) <b>10</b> = venting with de-energized solenoid <b>11</b> = venting with energized solenoid																	Voltage code, see section ⑩ (1)
Pressure range: <b>50</b> = 4÷50 bar (AGIR*); <b>100</b> = 6÷100 bar; <b>210</b> = 7÷210 bar; <b>350</b> = 8÷350 bar																	<b>X</b> = without connector (1): See section ⑨ for available connectors, to be ordered separately  <b>-00-AC</b> = AC solenoid valve without coils <b>-00-DC</b> = DC solenoid valve without coils
Options (2): <b>V</b> = regulating handwheel instead of a grub screw protected by cap <b>VF</b> = regulating knob instead of a grub screw protected by cap (only for AGIS, AGIU) <b>VS</b> = manual override with safety locking instead of a grub screw protected by cap (only for AGIS, AGIU)  Only for AGIU: <b>D</b> = internal drain <b>WP</b> = prolonged manual override protected by rubber cap (2) - = standard unloading characteristics <b>5, 6, 7</b> = other unloading characteristics, see section ⑧																	Pilot valve (1): <b>E</b> = DHE for AC and DC supply, high performances with <b>cURus</b> certified solenoids <b>L</b> = DHL for AC and DC supply, compact execution

(1) Only for AGIU with solenoid valve for venting

(2) For handwheel features, see technical table K150

(3) Not available for -L version (DHL pilot valve)

## 2 HYDRAULIC CHARACTERISTICS

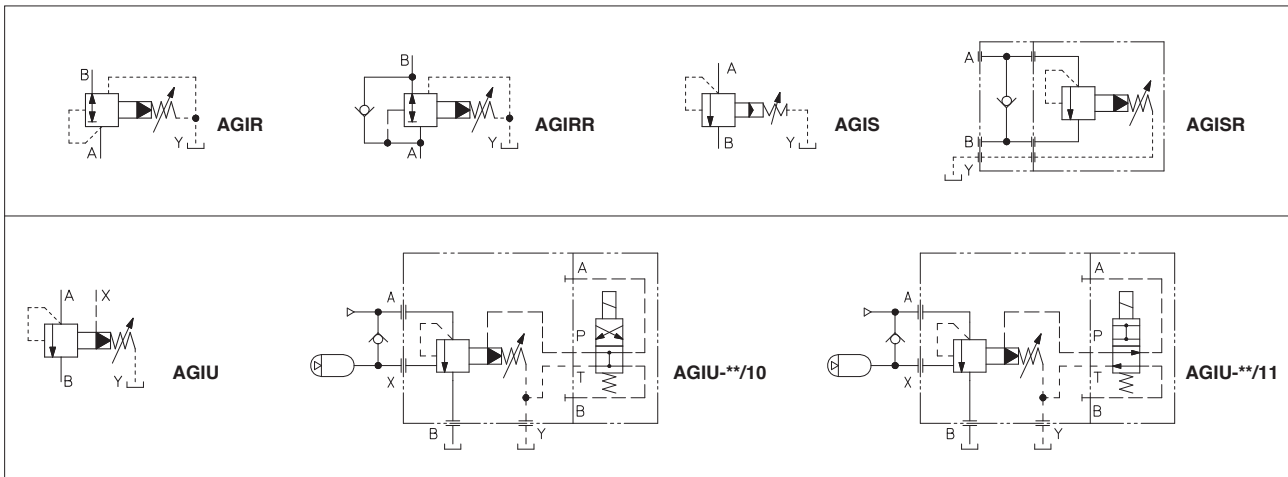

## 3 GENERAL CHARACTERISTICS

Assembly position	Any position
Subplate surface finishing to ISO 4401	Acceptable roughness index, Ra ≤0,8 recommended Ra 0,4 - flatness ratio 0,01/100
MTTFd valves according to EN ISO 13849	75 years for standard version, 75 years for venting option, see technical table P007
Ambient temperature range	<b>Standard</b> = -30°C ÷ +70°C <b>/PE</b> option = -20°C ÷ +70°C <b>/BT</b> option = -40°C ÷ +70°C
Storage temperature range	<b>Standard</b> = -30°C ÷ +80°C <b>/PE</b> option = -20°C ÷ +80°C <b>/BT</b> option = -40°C ÷ +80°C
Surface protection	Body: zinc coating with black passivation      Coil: zinc nickel coating (DC version) plastic encapsulation (AC version)
Corrosion resistance	Salt spray test (EN ISO 9227) > 200 h
Compliance	CE to Low Voltage Directive 2014/35/EU RoHS Directive 2011/65/EU as last update by 2015/863/EU REACH Regulation (EC) n°1907/2006

## 4 HYDRAULIC CHARACTERISTICS

Valve model	AGIR-10	AGIR-20	AGIR-32	AGIS-10	AGIS-20	AGIS-32	AGIU-10	AGIU-20	AGIU-32
Max flow [l/min]	160	300	400	200	400	600	100	200	300
Pressure range [bar]	4÷50 (AGIR*);			6÷100;		7÷210;		8÷350	
Max pressure [bar]	Ports A, B, X = 350 bar					Port Y = 0			

## 5 ELECTRICAL CHARACTERISTICS (for AGAM with pilot solenoid valve)

Insulation class	<b>H</b> (180°C) for DC coils; <b>F</b> (155°C) for AC coils Due to the occurring surface temperatures of the solenoid coils, the European standards EN ISO 13732-1 and EN ISO 4413 must be taken into account
Protection degree to DIN EN 60529	<b>IP 65</b> (with connectors correctly assembled)
Relative duty factor	100%
Supply voltage and frequency	See section <a href="#">10</a>
Supply voltage tolerance	± 10%
Certification	<b>cURus</b> North American standard - only for DHE pilot valve

## 6 SEALS AND HYDRAULIC FLUID - for other fluids not included in below table, consult our technical office

Seals, recommended fluid temperature	NBR seals (standard) = -20°C ÷ +80°C, with HFC hydraulic fluids = -20°C ÷ +50°C FKM seals (/PE option) = -20°C ÷ +80°C HNBR seals (/BT option) = -40°C ÷ +60°C, with HFC hydraulic fluids = -40°C ÷ +50°C		
Recommended viscosity	15÷100 mm²/s - max allowed range 2,8 ÷ 500 mm²/s		
Max fluid contamination level	ISO4406 class 20/18/15 NAS1638 class 9, see also filter section at <a href="http://www.atos.com">www.atos.com</a> or KTF catalog		
<b>Hydraulic fluid</b>	<b>Suitable seals type</b>	<b>Classification</b>	<b>Ref. Standard</b>
Mineral oils	NBR, FKM, HNBR	HL, HLP, HLPD, HVLP, HVLPD	DIN 51524
Flame resistant without water	FKM	HFDU, HFDR	ISO 12922
Flame resistant with water	NBR, HNBR	HFC	

**7 REGULATED PRESSURE VERSUS FLOW DIAGRAMS** based on mineral oil ISO VG 46 at 50°C

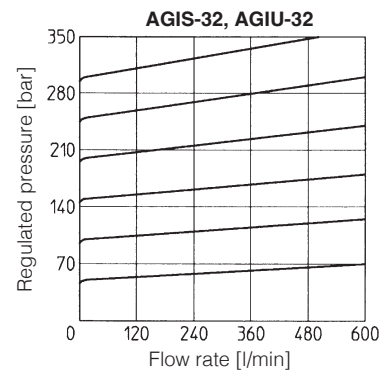
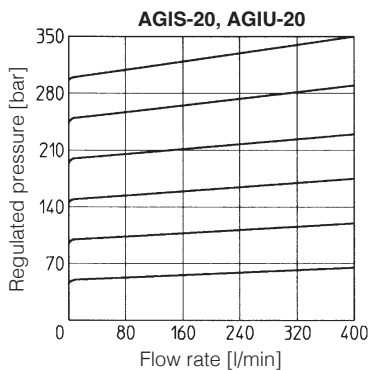
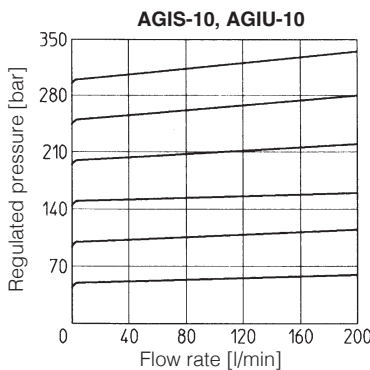
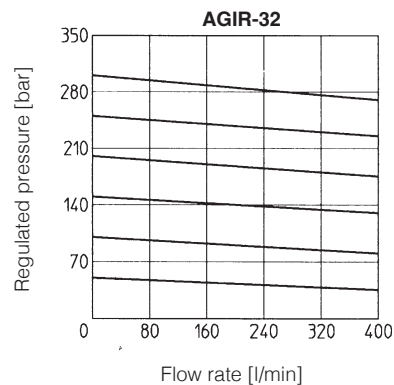
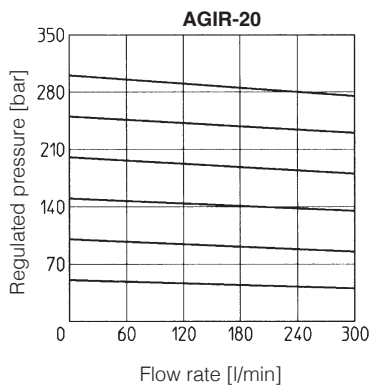
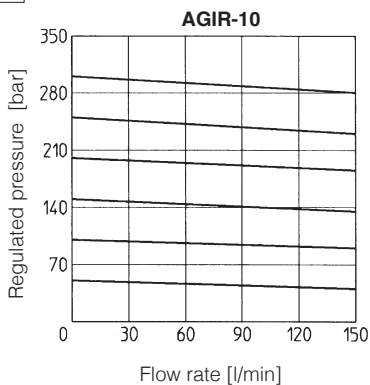

**Note:** for AGIU-10, the max flow rate is 100 l/min

**Note:** for AGIU-20, the max flow rate is 200 l/min

**Note:** for AGIU-32, the max flow rate is 300 l/min

**8 OPERATING DIAGRAM** based on mineral oil ISO VG 46 at 50°C

- 1 = AGIR-10 A → B
- 2 = AGIR-20 A → B
- 3 = AGIR-32 A → B
- 4 = AGIR-10 B → A
- 5 = AGIR-20 B → A
- 6 = AGIR-32 B → A

- 7 = AGIS-10
- 8 = AGIS-20
- 9 = AGIS-32

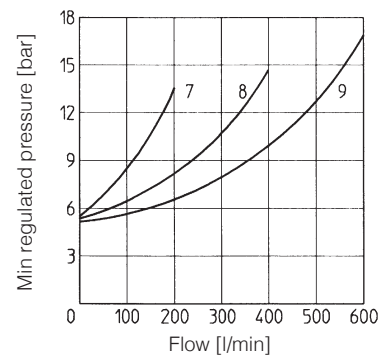
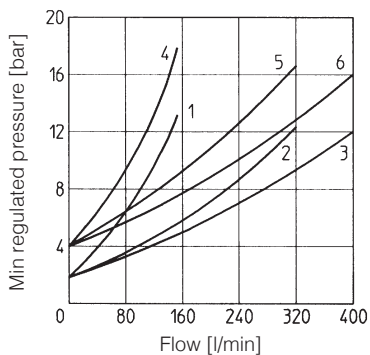

**Opening/closing diagram for AGIU**

- 1 = AGIU-\*/.../standard    3 = AGIU-\*/.../6
- 2 = AGIU-\*/.../5         4 = AGIU-\*/.../7

**NOTES**

- 1) Short pipes with low resistance must be used between the unloading valve and the accumulator;
- 2) When the resistance is high, the hydraulic pilot signal must be taken as closed as possible to the accumulator;
- 3) With high pump flow and small valve differential pressure of intervention it is advisable to use the version with external drain;
- 4) When to use the BA-\*25 subplates:
  - a) in applications with working frequencies >10 Hz use subplates type BA-\*25/4 (spring with 4 bar of cracking pressure);
  - b) in applications with working frequencies <10 Hz use subplates type BA-\*25/2 (spring with 2 bar of cracking pressure);

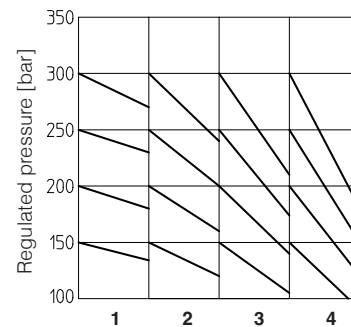
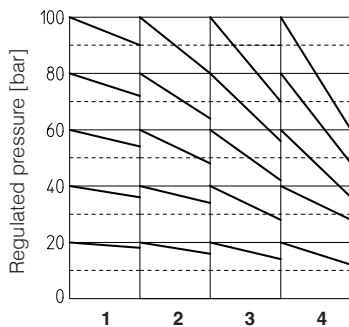

**9 ELECTRIC CONNECTORS ACCORDING TO DIN 43650** for AGIU with solenoid valve (to be ordered separately, see tech table K800)

**666** = standard connector IP-65, suitable for direct connection to electric supply source

**667** = as 666, but with built-in signal led. Available for power supply voltage 24 AC or DC, 110 AC or DC, 220 AC or DC

**10 COIL VOLTAGE**

External supply nominal voltage ± 10%	Voltage code	Type of connector	-EX Power consumption (2)	-LX Power consumption (2)	Code of spare coil -EX	Code of spare coil -LX
12 DC	<b>12 DC</b>	666 or 667	30W	29W	COE-12DC	COL-12DC
14 DC	<b>14 DC</b>				COE-14DC	COL-14DC
110 DC	<b>110 DC</b>				COE-110DC	COL-110DC
220 DC	<b>220 DC</b>				COE-220DC	COL-220DC
110/50 AC (1)	<b>110/50/60 AC</b>	666 or 667	58VA (3)	58VA (3)	COE-110/50/60AC	COL-110/50/60AC
115/60 AC	<b>115/60 AC</b>		80VA (3)		COE-115/60AC	COL-115/60AC
230/50 AC (1)	<b>230/50/60 AC</b>		58VA (3)		COE-230/50/60AC	COL-230/50/60AC
230/60 AC	<b>230/60 AC</b>		80VA (3)		COE-230/60AC	COL-230/60AC

(1) For other supply voltages available on request see technical tables E015, E018.

(2) Coil can be supplied also with 60 Hz of voltage frequency: in this case the performances are reduced by 20 - 25% and the power consumption is 55 VA (DHL) and 58 VA (DHE)

(3) Average values based on tests performed at nominal hydraulic condition and ambient/coil temperature of 20°C.

(4) When solenoid is energized, the inrush current is approx 3 times the holding current.

**11 DIMENSIONS [mm]**

**AGIR, AGIS, AGIU size 10**

**ISO 5781: 2000**

**Mounting surface: 5781-06-07-0-00**

Fastening bolts:

4 socket head screws M10x45 class 12.9

Tightening torque = 70 Nm

Seals: 2 OR 109/70, 2 OR 3068

Ports A, B: Ø = 14 mm

Ports X, Y: Ø = 5 mm

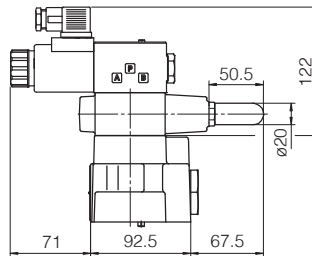
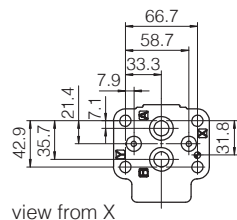

**AGIU-10/\*\*-EX**  
Mass = 5,6 Kg

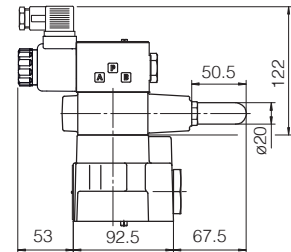

**AGIU-10/\*\*-LX**  
Mass = 5,4 Kg

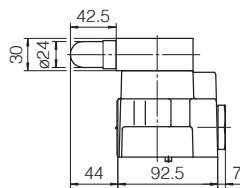

**AGIR-10;** Mass = 3,3 Kg  
**AGIRR-10;** Mass = 3,5 Kg

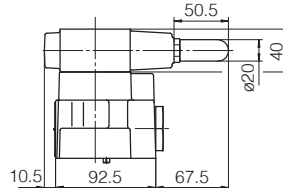
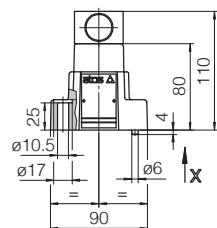

**AGIS-10;** Mass = 3,8 Kg  
**AGIU-10;** Mass = 3,8 Kg

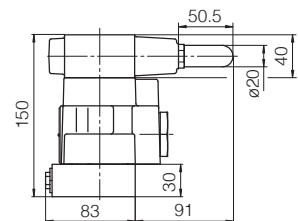

**AGISR-10;** Mass = 5,3 Kg

Overall dimensions refer to valves **DC** voltage, with connectors type 666

**AGIR, AGIS, AGIU size 20**

**ISO 5781: 2000**

**Mounting surface: 5781-08-10-0-00**

Fastening bolts:

4 socket head screws M10x45 class 12.9

Tightening torque = 70 Nm

Seals: 2 OR 109/70, 2 OR 4100

Ports A, B: Ø = 22 mm

Ports X, Y: Ø = 5 mm

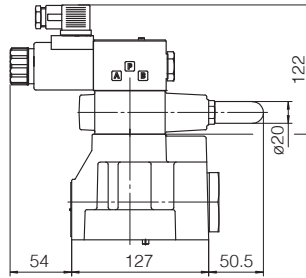
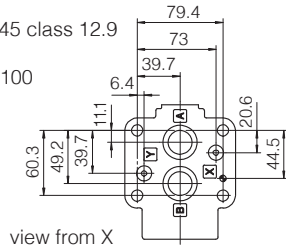

**AGIU-20/10/\*\*-EX**  
Mass = 7,8 Kg

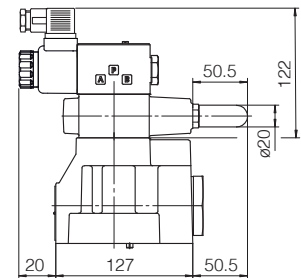

**AGIU-20/10/\*\*-LX**  
Mass = 7,6 Kg

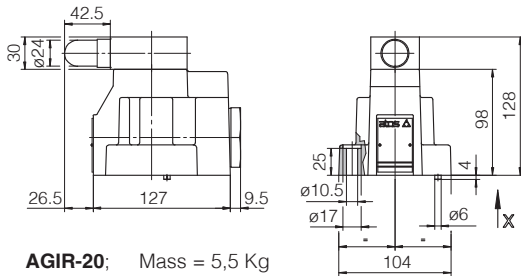

**AGIR-20;** Mass = 5,5 Kg  
**AGIRR-20;** Mass = 5,7 Kg

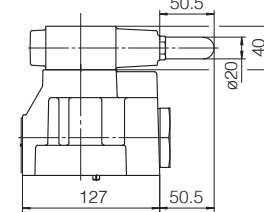

**AGIS-20;** Mass = 6 Kg  
**AGIU-20;** Mass = 6 Kg

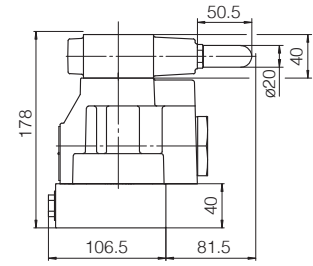

**AGISR-20;** Mass = 9 Kg

**AGIR, AGIS, AGIU size 32**

**ISO 5781: 2000**

**Mounting surface: 5781-10-13-0-00**

Fastening bolts:

6 socket head screws M10x45 class 12.9

Tightening torque = 70 Nm

Seals: 2 OR 109/70, 2 OR 4131

Ports A, B: Ø = 28 mm

Ports X, Y: Ø = 5 mm

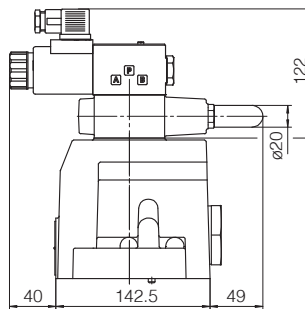
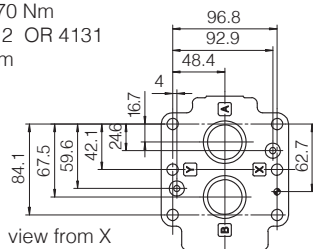

**AGIU-32/10/\*\*-EX**  
Mass = 11,7 Kg

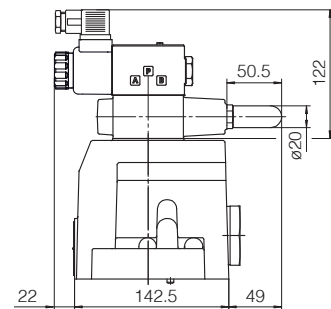

**AGIU-32/10/\*\*-LX**  
Mass = 11,5 Kg

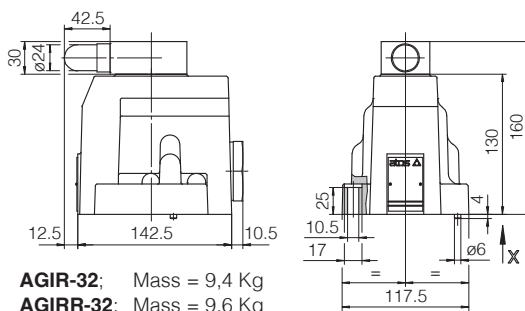

**AGIR-32;** Mass = 9,4 Kg  
**AGIRR-32;** Mass = 9,6 Kg

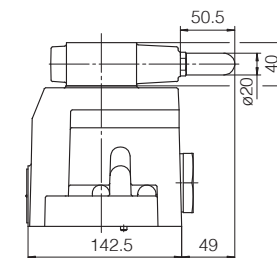

**AGIS-32;** Mass = 9,9 Kg  
**AGIU-32;** Mass = 9,9 Kg

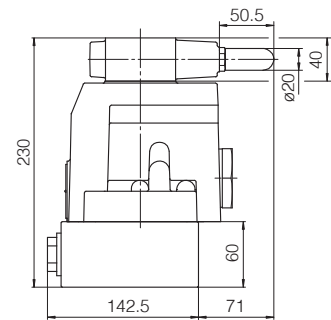

**AGISR-32;** Mass = 15,5 Kg

Overall dimensions refer to valves DC voltage, with connectors type 666

**12 MOUNTING SUBPLATES**

Valve	Subplate model	Port location	Ports				Ø Counterbore [mm]				Mass [Kg]
			A	B	X-Y	OUT	A	B	X-Y	OUT	
AGI*-10	BA-305	Ports A, B, Y underneath;	G 1/2"	G 1/2"	G 1/4"	-	30	30	21,5	-	1
AGI*-20	BA-505		G 1"	G 1"	G 1/4"	-	46	46	21,5	-	2
AGI*-32	BA-705		G 1 1/2"	G 1 1/2"	G 1/4"	-	63,5	63,5	21,5	-	7,5

The subplates are supplied with fastening bolts. For further details see table K280