

Digital proportional directional valves

piloted, without transducer, with positive spool overlap

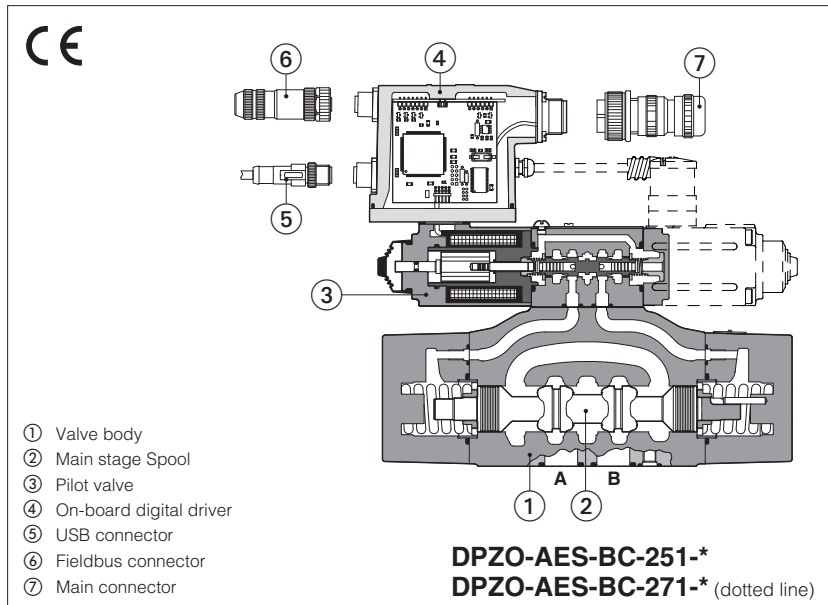

DPZO-A, DPZO-AEB, DPZO-AES

Digital proportional valves without position transducer and with positive spool overlap, for open loop directional controls and not compensated flow regulations.

A to be coupled with off-board drivers.

AEB basic execution, with on-board digital driver, analog reference signals and USB port for software functional parameters setting.

AES full execution, with on-board digital driver which includes also fieldbus interface for functional parameters setting, reference signals and real-time diagnostics.

Size: **10 ÷ 32** - ISO 4401

Max flow: **180 ÷ 1500 l/min**

Max pressure: **350 bar**

1 MODEL CODE

DPZO	-	AES	-	BC	-	2		71	-	L		5	/	*	/	*	/	*	/	*
Proportional directional valve, piloted																				
A = for off-board driver, see section 2 AEB = basic on-board digital driver (1) AES = full on-board digital driver (2)																				
Fieldbus interfaces , USB port always present (5): NP = Not present BC = CANopen BP = PROFIBUS DP EH = EtherCAT																				
Valve size ISO 4401: 1 = 10 2 = 16 4 = 25 6 = 32																				
		Seals material , see section 8: - = NBR PE = FKM BT = HNBR Series number																		
		Coil voltage , only for A - see section 14: - = standard coil for 24Vdc Atos drivers 6 = optional coil for 12Vdc Atos drivers 18 = optional coil for low current drivers																		

Configuration (3):

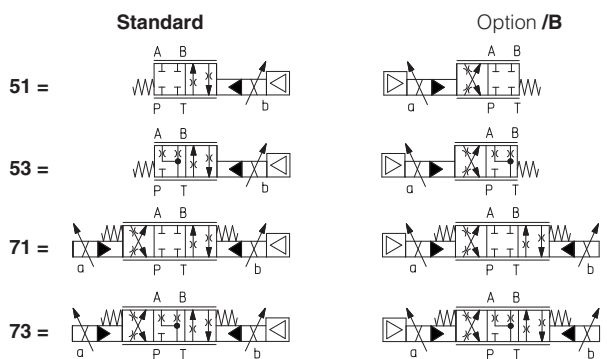

Spool type, regulating characteristics:

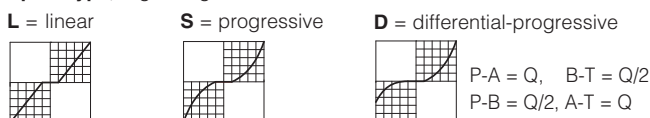

Hydraulic options (4):

B = solenoid and on-board digital driver at side of port B of the main stage (side A of pilot valve)

D = internal drain

E = external pilot pressure

G = pressure reducing valve for piloting

Electronics options, only for AEB and AES (4):

C = current feedback for pressure transducer 4÷20 mA (omit for std voltage 0÷10 Vdc) - only for **W**

I = current reference input 4÷20 mA (omit for std voltage ±10 Vdc)

Q = enable signal

Z = double power supply, enable, fault and monitor signals -12 pin connector

W = power limitation function - 12 pin connector

Spool size: 3 (L,S,D) 5 (L,S,D)

DPZO-1 =	-	100
DPZO-2 =	160	250
DPZO-4 =	-	480
DPZO-6 =	-	640

Nominal flow (l/min) at Δp 10bar P-T

(1) Only for NP

(2) Only for BC, BP, EH

(3) Hydraulic symbols are represented with on-board digital driver

(4) For possible combined options, see section 13

(5) Omit for A execution

2 OFF-BOARD ELECTRONIC DRIVERS - only for A

Drivers model	E-MI-AC-01F		E-MI-AS-IR		E-BM-AS-PS		E-BM-AES
Type	Analog				Digital		
Voltage supply (VDC)	12	24	12	24	12	24	24
Valve coil option	/6	std	/6	std	/6	std	std
Format	plug-in to solenoid				DIN-rail panel		
Tech table	G010		G020		G030		GS050

3 GENERAL NOTES

Atos digital proportionals valves are CE marked according to the applicable directives (e.g. Immunity and Emission EMC Directive). Installation, wirings and start-up procedures must be performed according to the general prescriptions shown in tech table **FS900** and in the user manuals included in the E-SW-* programming software.

4 VALVE SETTINGS AND PROGRAMMING TOOLS

Valve's functional parameters and configurations, can be easily set and optimized using Atos E-SW programming software connected via USB port to the digital driver. For fieldbus versions, the software permits valve's parameterization through USB port also if the driver is connected to the central machine unit via fieldbus.

The software is available in different versions according to the driver's options (see table **GS500**):

E-SW-BASIC	support: NP (USB)	PS (Serial)	IR (Infrared)
E-SW-FIELDBUS	support: BC (CANopen)	BP (PROFIBUS DP)	EH (EtherCAT)
	EW (POWERLINK)	EI (EtherNet/IP)	EP (PROFINET)
E-SW-*/PQ	support: valves with SP, SF, SL alternated control (e.g. E-SW-BASIC/PQ)		



WARNING: drivers USB port is not isolated! For E-C-SB-USB/M12 cable, the use of isolator adapter is highly recommended for PC protection



WARNING: see tech table **GS500** for the list of countries where the Bluetooth adapter has been approved

USB or Bluetooth connection

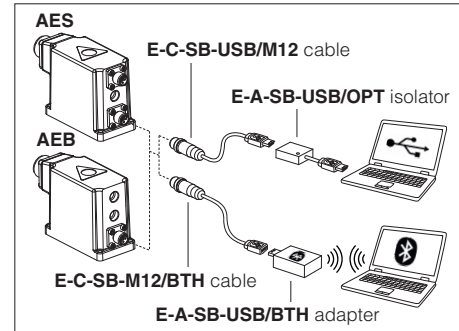

5 FIELDBUS - only for AES, see tech. table **GS510**

Fieldbus allows valve direct communication with machine control unit for digital reference, valve diagnostics and settings. These execution allow to operate the valves through fieldbus or analog signals available on the main connector.

6 GENERAL CHARACTERISTICS

Assembly position	Any position
Subplate surface finishing to ISO 4401	Acceptable roughness index: Ra ≤ 0,8, recommended Ra 0,4 – Flatness ratio 0,01/100
MTTFd valves according to EN ISO 13849	75 years, see technical table P007
Ambient temperature range	A: Standard = -20°C ÷ +70°C /PE option = -20°C ÷ +70°C /BT option = -40°C ÷ +60°C AEB, AES: Standard = -20°C ÷ +60°C /PE option = -20°C ÷ +60°C /BT option = -40°C ÷ +60°C
Storage temperature range	A: Standard = -20°C ÷ +80°C /PE option = -20°C ÷ +80°C /BT option = -40°C ÷ +70°C AEB, AES: Standard = -20°C ÷ +70°C /PE option = -20°C ÷ +70°C /BT option = -40°C ÷ +70°C
Surface protection	Zinc coating with black passivation, galvanic treatment (driver housing for AEB and AES)
Corrosion resistance	Salt spray test (EN ISO 9227) > 200 h
Compliance	CE according to EMC directive 2014/30/EU (Immunity: EN 61000-6-2; Emission: EN 61000-6-3) RoHS Directive 2011/65/EU as last update by 2015/863/EU REACH Regulation (EC) n°1907/2006

7 HYDRAULIC CHARACTERISTICS - based on mineral oil ISO VG 46 at 50 °C

Valve model	DPZO-*-1	DPZO-*-2		DPZO-*-4	DPZO-*-6
Pressure limits [bar]	ports P, A, B, X = 350; T = 250 (10 with internal drain /D) Y = 10				
Spool type	L5, S5, D5	L3, S3, D3		L5, S5, D5	
Nominal flow Δp P-T [l/min]					
(1) Δp= 10 bar	100	160	250	480	640
Δp= 30 bar	160	270	430	830	1100
Max permissible flow	180	400	550	900	1500
Piloting pressure [bar]	min = 25; max = 350 (option /G advisable for pilot pressure > 150 bar)				
Piloting volume [cm³]	1,4	3,7		9,0	21,6
Piloting flow (2) [l/min]	1,7	3,7		6,8	14,4
Leakage (3) [l/min]	0,15 / 0,5	0,2 / 0,6		0,3 / 1,0	1,0 / 3,0
Response time (4) [ms]	≤ 80	≤ 100		≤ 120	≤ 180
Hysteresis	≤ 5 [% of max regulation]				
Repeatability	± 1 [% of max regulation]				

Note: above performance data refer to valves coupled with Atos electronic drivers, see section 2

(1) For different Δp, the max flow is in accordance to the diagrams in section 9.2

(2) With step reference input signal 0 ÷ 100 %

(3) At p = 100/350 bar

(4) 0-100% step signal

8 ELECTRICAL CHARACTERISTICS

Power supplies	Nominal : +24 VDC Rectified and filtered : VRMS = 20 ÷ 32 VMAX (ripple max 10 % VPP)			
Max power consumption	A = 30 W AEB, AES = 50 W			
Coil voltage code	standard	option /6	option /18	
Max. solenoid current	2,2 A	2,75 A	1 A	
Coil resistance R at 20°C	3 ÷ 3,3 Ω	2 ÷ 2,2 Ω	13 ÷ 13,4 Ω	
Analog input signals	Voltage: range ±10 VDC (24 VMAX tollerant) Current: range ±20 mA		Input impedance: Ri > 50 kΩ Input impedance: Ri = 500 Ω	
Monitor output	Output range: voltage ±5 VDC @ max 5 mA			
Enable input	Range: 0 ÷ 9 VDC (OFF state), 15 ÷ 24 VDC (ON state), 9 ÷ 15 VDC (not accepted); Input impedance: Ri > 87 kΩ			
Fault output	Output range : 0 ÷ 24 VDC (ON state ≡ VL+ [logic power supply] ; OFF state ≡ 0 V) @ max 50 mA; external negative voltage not allowed (e.g. due to inductive loads)			
Pressure transducer power supply (only for /W option)	+24VDC @ max 100 mA (E-ATR-8 see tech table GS465)			
Alarms	Solenoid not connected/short circuit, cable break with current reference signal, over/under temperature, current control monitoring, power supplies level, pressure transducer failure (/W option)			
Insulation class	H (180°) Due to the occuring surface temperatures of the solenoid coils, the European standards ISO 13732-1 and EN982 must be taken into account			
Protection degree to DIN EN60529	A = IP65; AEB, AES = IP66 / IP67 with mating connectors			
Duty factor	Continuous rating (ED=100%)			
Tropicalization	Tropical coating on electronics PCB			
Additional characteristics	Short circuit protection of solenoid's current supply; current control by P.I.D. with rapid solenoid switching; protection against reverse polarity of power supply			
Communication interface	USB Atos ASCII coding	CANopen EN50325-4 + DS408	PROFIBUS DP EN50170-2/IEC61158	EtherCAT EC 61158
Communication physical layer	not insulated USB 2.0 + USB OTG	optical insulated CAN ISO11898	optical insulated RS485	Fast Ethernet, insulated 100 Base TX
Recommended wiring cable	LiYCY shielded cables, see section 17			

Note: a maximum time of 500 ms (depending on communication type) have be considered between the driver energizing with the 24 V_{DC} power supply and when the valve is ready to operate. During this time the current to the valve coils is switched to zero.

9 SEALS AND HYDRAULIC FLUIDS - for other fluids not included in below table, consult our technical office

Seals, recommended fluid temperature	NBR seals (standard) = -20°C ÷ +60°C (+80°C for A), with HFC hydraulic fluids = -20°C ÷ +50°C FKM seals (/PE option) = -20°C ÷ +80°C HNBR seals (/BT option) = -40°C ÷ +60°C, with HFC hydraulic fluids = -40°C ÷ +50°C		
Recommended viscosity	20 ÷ 100 mm ² /s - max allowed range 15 ÷ 380 mm ² /s		
Max fluid contamination level	normal operation	ISO4406 class 18/16/13 NAS1638 class 7	see also filter section at
	longer life	ISO4406 class 16/14/11 NAS1638 class 5	www.atos.com or KTF catalog
Hydraulic fluid	Suitable seals type	Classification	Ref. Standard
Mineral oils	NBR, FKM, HNBR	HL, HLP, HLPD, HVLP, HVLPD	DIN 51524
Flame resistant without water	FKM	HFDU, HFDR	ISO 12922
Flame resistant with water	NBR, HNBR	HFC	

10 DIAGRAMS (based on mineral oil ISO VG 46 at 50 °C)

10.1 Regulation diagrams (values measure at Δp 10 bar P-T)

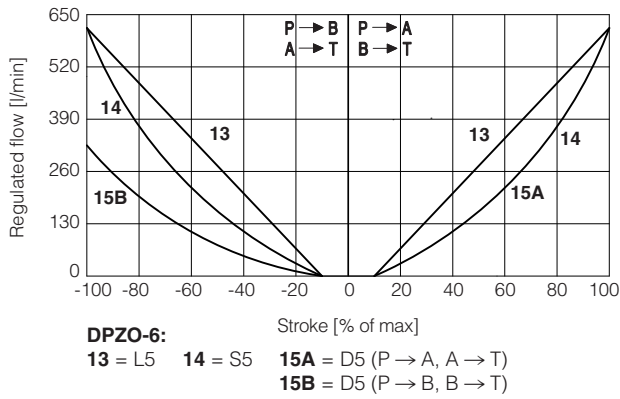
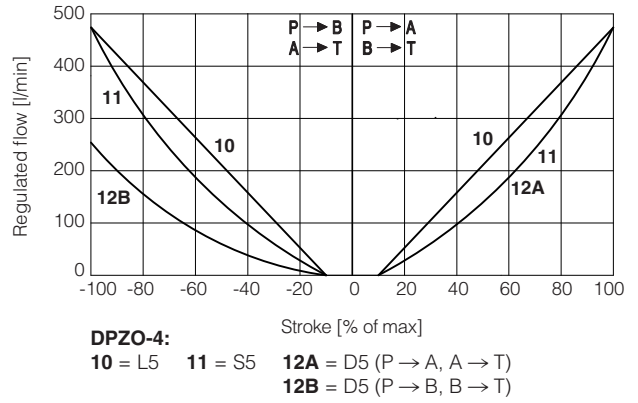
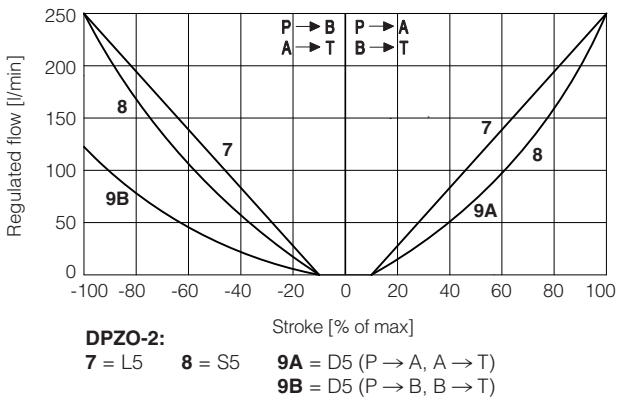
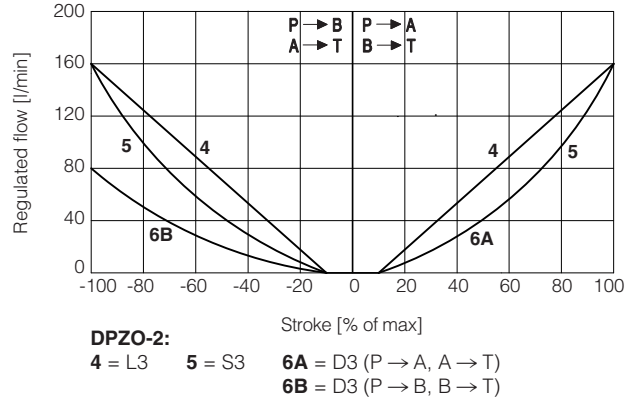
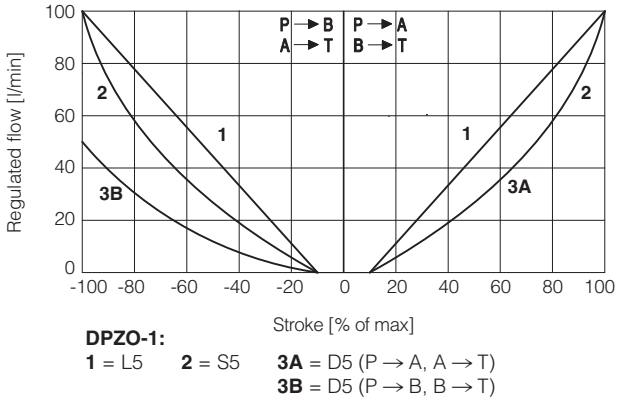

Note: Hydraulic configuration vs. reference signal for configuration 71 and 73 (standard and option /B)

Reference signal $\left. \begin{matrix} 0 \div +10 \text{ V} \\ 12 \div 20 \text{ mA} \end{matrix} \right\} P \rightarrow A / B \rightarrow T$

Reference signal $\left. \begin{matrix} 0 \div -10 \text{ V} \\ 12 \div 4 \text{ mA} \end{matrix} \right\} P \rightarrow B / A \rightarrow T$

10.2 Flow / Δp diagram

stated at 100% of spool stroke

DPZO-1:

1 = spools L5, S5, D5

DPZO-2:

2 = spools L3, S3, D3

3 = spools L5, S5, D5

DPZO-4:

4 = spools L5, S5, D5

DPZO-6:

5 = spools L5, S5, D5

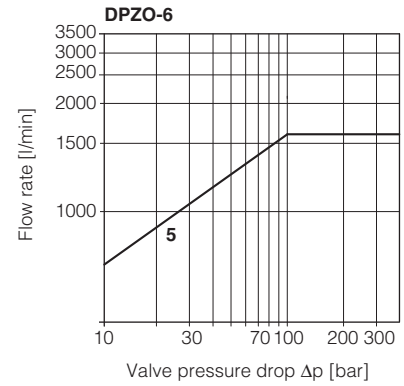
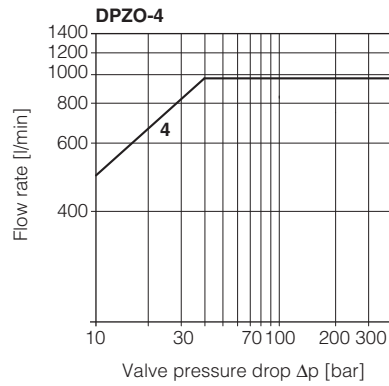
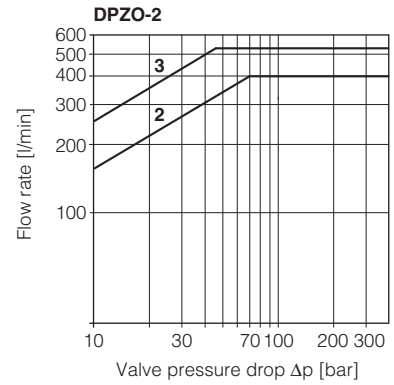
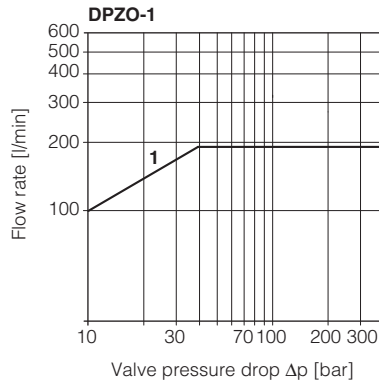

10.3 Response time (measured at pilot pressure = 100 bar)

The response times in below diagrams are measured at different steps of the reference input signal. They have to be considered as average values. For the valves with digital electronics the dynamics performances can be optimized by setting the internal software parameters.

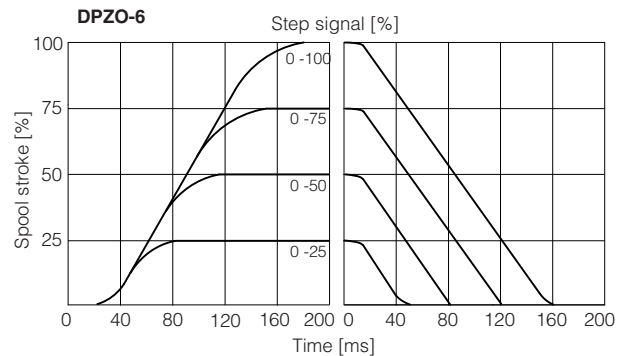
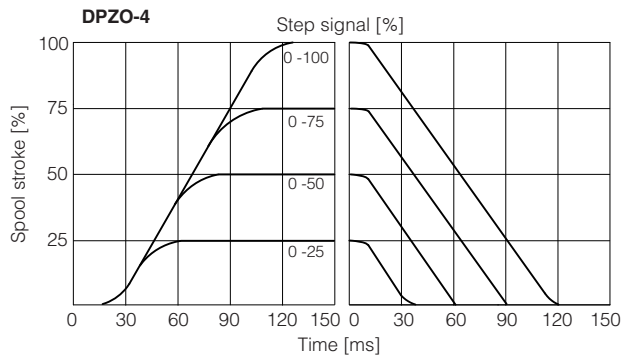
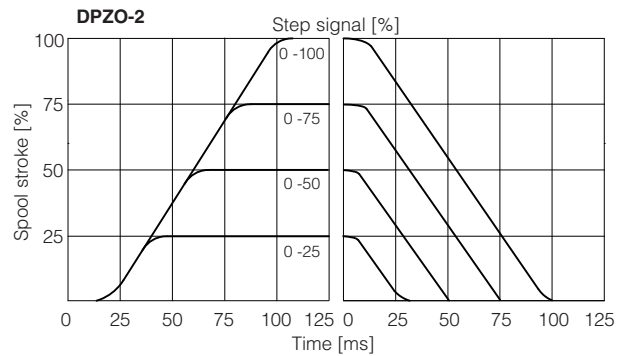
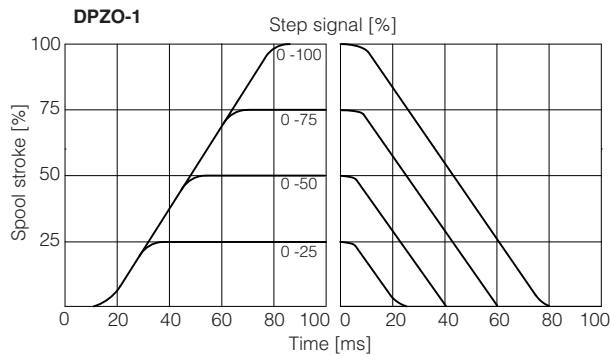

10.4 Operation as throttle valve

Single solenoid valves (*51) can be used as simple throttle valves:
 $P_{max} = 250 \text{ bar}$
 For this application, the use of valve -TEB or -TES (see tab. FS172) is advisable (consult our technical office)

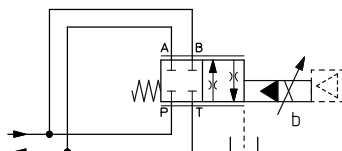

DPZO-*	151-L5	251-L5	451-L5	651-L5
Max flow [l/min] $\Delta p = 15 \text{ bar}$	320	860	1600	2200

11 HYDRAULIC OPTIONS

- B** = DPZO-*-*5 = solenoid and on-board digital driver at side B of the main stage (side A of pilot valve).
DPZO-*-*7 = on-board digital driver at side of port B of the main stage (side A of pilot valve).
- D** = Internal drain.
Pilot and drain configuration can be modified as shown in section 18.
The valve's standard configuration provides internal pilot and external drain.
- E** = External pilot (through port X).
Pilot and drain configuration can be modified as shown in section 18.
The valve's standard configuration provides internal pilot and external drain.
- G** = Pressure reducing valve installed between pilot valve and main body with fixed setting:
DPZO-1 and DPZO-2 = **40 bar**
DPZO-4 and DPZO-6 = **100 bar**
It is advisable for valves with internal pilot in case of system pressure higher than 150 bar.

12 ELECTRONICS OPTIONS - only for AEB and AES

- I** = This option provides 4 ÷ 20 mA current reference and monitor signals, instead of the standard ±10 Vdc.
Input signal can be reconfigured via software selecting between voltage and current, within a maximum range of ±10 Vdc or ±20 mA.
It is normally used in case of long distance between the machine control unit and the valve or where the reference signal can be affected by electrical noise; the valve functioning is disabled in case of reference signal cable breakage.
- Q** = This option permits to inhibit the valve function without removing the power supply to the driver.
Upon disable command the current to the solenoid is zeroed and the valve's spool moves to rest position.
The option /Q is suggested for all cases where the valve has to be frequently inhibited during the machine cycle – see 15.5 for signal specifications.
- Z** = This option provides, on the 12 pin main connector, the following additional features:
Fault output signal - see 15.6
Enable input signal - see above option /Q
Power supply for driver's logics and communication - see 15.2
- C** = Only in combination with option /W
This option is available to connect pressure transducers with 4 ÷ 20 mA current output signal, instead of the standard ±10 Vdc.
Input signal can be reconfigured via software selecting between voltage and current, within a maximum range of ±10 Vdc or ±20 mA.
- W** = Only for valves coupled with pressure compensator, see tech table D150.
It provides the hydraulic power limitation function. The driver receives the flow reference signal by the analog input INPUT+ and a pressure transducer, installed in the hydraulic system, has to be connected to the driver's analog input TR. When the actual requested hydraulic power $p \times Q$ (TR x INPUT+) reaches the max power limit ($p_1 \times Q_1$), internally set by software, the driver automatically reduces the flow regulation of the valve. The higher is the pressure feedback the lower is the valve's regulated flow:

$$\text{Flow regulation} = \text{Min} \left(\frac{\text{PowerLimit [sw setting]}}{\text{Transducer Pressure [TR]}} ; \text{Flow Reference [INPUT+]} \right)$$

13 POSSIBLE COMBINED OPTIONS

- Hydraulic options:** all combination possible
Electronics options: /IQ, /IZ, /IW, /ICW, /ICWI

14 COIL VOLTAGE OPTIONS - only for A

- 6** = Optional coil to be used with Atos drivers with power supply 12 Vdc.
18 = Optional coil to be used with electronic drivers not supplied by Atos, with power supply 24 Vdc and with max current limited to 1A.

15 POWER SUPPLY AND SIGNALS SPECIFICATIONS - only for AEB and AES

Generic electrical output signals of the valve (e.g. fault or monitor signals) must not be directly used to activate safety functions, like to switch-ON/OFF the machine's safety components, as prescribed by the European standards (Safety requirements of fluid technology systems and components-hydraulics, ISO 4413).

15.1 Power supply (V+ and V0)

The power supply must be appropriately stabilized or rectified and filtered: apply at least a 10000 µF/40 V capacitance to single phase rectifiers or a 4700 µF/40 V capacitance to three phase rectifiers. In case of separate power supply see 15.2.



A safety fuse is required in series to each power supply: 2,5 A time lag fuse.

15.2 Power supply for driver's logic and communication (VL+ and VL0) - only for /Z and /W options

The power supply for driver's logic and communication must be appropriately stabilized or rectified and filtered: apply at least a 10000 µF/40 V capacitance to single phase rectifiers or a 4700 µF/40 V capacitance to three phase rectifiers.
The separate power supply for driver's logic on pin 9 and 10, allow to remove solenoid power supply from pin 1 and 2 maintaining active the diagnostics, USB and fieldbus communications.



A safety fuse is required in series to each driver's logic and communication power supply: 500 mA fast fuse.

15.3 Reference input signal (INPUT+)

The driver controls in closed loop the current to the valve proportionally to the external reference input signal.
Reference input signal is factory preset according to selected valve code, defaults are ±10 Vdc for standard and 4 ÷ 20 mA for /I option.
Input signal can be reconfigured via software selecting between voltage and current, within a maximum range of ±10 Vdc or ±20 mA.
Drivers with fieldbus interface (BC, BP, EH) can be software set to receive reference signal directly from the machine control unit (fieldbus reference). Analog reference input signal can be used as on-off commands with input range 0 ÷ 24Vdc.

Functional Scheme

Example of configuration 7*
3 positions, spring centered

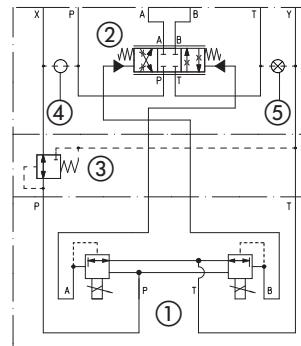

- ① Pilot valve
② Main stage
③ Pressure reducing valve
④ Plug to be added for external pilot trough port X
⑤ Plug to be removed for internal drain through port T

Hydraulic Power Limitation

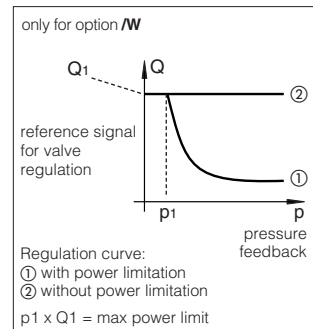

15.4 Monitor output signals (MONITOR and MONITOR2)

The driver generates an analog output signal (MONITOR) proportional to the actual coil current of the valve; the monitor output signal can be software set to show other signals available in the driver (e.g. analog reference, fieldbus reference).
 Monitor output signal is factory preset according to selected valve code, default settings is $\pm 5 V_{DC}$ ($1V = 1A$).
 Output signal can be reconfigured via software, within a maximum range of $\pm 5 V_{DC}$.

Option /W

The driver generates a second analog output signal (MONITOR2) proportional to the actual system pressure.
 The output maximum range is $\pm 5 V_{DC}$; default setting is $0 \div 5 V_{DC}$.

15.5 Enable input signal (ENABLE) - not for standard

To enable the driver, supply a $24 V_{DC}$ on pin 3 (pin C): Enable input signal allows to enable/disable the current supply to the solenoid, without removing the electrical power supply to the driver; it is used to activate the communication and the other driver functions when the valve must be disabled for safety reasons. This condition **does not comply** with norms IEC 61508 and ISO 13849.
 Enable input signal can be used as generic digital input by software selection.

15.6 Fault output signal (FAULT) - only for /Z and /W options

Fault output signal indicates fault conditions of the driver (solenoid short circuits/not connected, reference signal broken for $4 \div 20$ mA input, etc.).
 Fault presence corresponds to $0 V_{DC}$, normal working corresponds to $24 V_{DC}$.
 Fault status is not affected by the Enable input signal.

15.7 Remote pressure transducer input signal (TR+) - only for /W option

Analog pressure transducers can be directly connected to the driver (see 16.4).
 Analog input signal is factory preset according to selected driver code, defaults are $0 \div 10 V_{DC}$ for standard and $4 \div 20$ mA for /C option.
 Input signal can be reconfigured via software selecting between voltage and current, within a maximum range of $\pm 10 V_{DC}$ or ± 20 mA.
 Note: transducer feedback can be read as a digital information through fieldbus communication - software selectable.

16 ELECTRONIC CONNECTIONS

16.1 Main connector signals - 7 pin (A1) Standard and /Q option - for AEB and AES

PIN	Standard	/Q	TECHNICAL SPECIFICATIONS	NOTES
A	V+		Power supply $24 V_{DC}$	Input - power supply
B	V0		Power supply $0 V_{DC}$	Gnd - power supply
C	AGND		Analog ground	Gnd - analog signal
		ENABLE	Enable ($24 V_{DC}$) or disable ($0 V_{DC}$) the driver, referred to V0	Input - on/off signal
D	INPUT+		Reference input signal: $\pm 10 V_{DC}$ / ± 20 mA maximum range Defaults are $\pm 10 V_{DC}$ for standard and $4 \div 20$ mA for /I option	Input - analog signal Software selectable
E	INPUT-		Negative reference input signal for INPUT+	Input - analog signal
F	MONITOR referred to: AGND V0		Monitor output signal: $\pm 5 V_{DC}$ maximum range Default is $\pm 5 V_{DC}$ ($1V = 1A$)	Output - analog signal Software selectable
G	EARTH		Internally connected to driver housing	

16.2 Main connector signals - 12 pin (A2) /Z and /W options - for AEB and AES

PIN	/Z	/W	TECHNICAL SPECIFICATIONS	NOTES
1	V+		Power supply $24 V_{DC}$	Input - power supply
2	V0		Power supply $0 V_{DC}$	Gnd - power supply
3	ENABLE		Enable ($24 V_{DC}$) or disable ($0 V_{DC}$) the driver, referred to VL0	Input - on/off signal
4	INPUT+		Reference input signal: $\pm 10 V_{DC}$ / ± 20 mA maximum range Defaults are $\pm 10 V_{DC}$ for standard and $4 \div 20$ mA for /I option	Input - analog signal Software selectable
5	INPUT-		Negative reference input signal for INPUT+	Input - analog signal
6	MONITOR		Monitor output signal: $\pm 5 V_{DC}$ maximum range, referred to VL0 Default is $\pm 5 V_{DC}$ ($1V = 1A$)	Output - analog signal Software selectable
7	NC		Do not connect	
8	NC		Do not connect	
		MONITOR2	2nd monitor output signal: $\pm 5 V_{DC}$ maximum range, referred to VL0. Default is $0 \div 5 V_{DC}$	Output - analog signal
9	VL+		Power supply $24 V_{DC}$ for driver's logic and communication	Input - power supply
10	VL0		Power supply $0 V_{DC}$ for driver's logic and communication	Gnd - power supply
11	FAULT		Fault ($0 V_{DC}$) or normal working ($24 V_{DC}$), referred to VL0	Output - on/off signal
PE	EARTH		Internally connected to driver housing	

Note: do not disconnect VL0 before VL+ when the driver is connected to PC USB port

16.3 Communication connectors - for AEB (B) and AES (B) - (C)

(B) USB connector - M12 - 5 pin always present		
PIN	SIGNAL	TECHNICAL SPECIFICATION (1)
1	+5V_USB	Power supply
2	ID	Identification
3	GND_USB	Signal zero data line
4	D-	Data line -
5	D+	Data line +

(C1) BC fieldbus execution, connector - M12 - 5 pin (2)		
PIN	SIGNAL	TECHNICAL SPECIFICATION (1)
1	CAN_SHLD	Shield
2	NC	do not connect
3	CAN_GND	Signal zero data line
4	CAN_H	Bus line (high)
5	CAN_L	Bus line (low)

(C2) BP fieldbus execution, connector - M12 - 5 pin (2)		
PIN	SIGNAL	TECHNICAL SPECIFICATION (1)
1	+5V	Termination supply signal
2	LINE-A	Bus line (high)
3	DGND	Data line and termination signal zero
4	LINE-B	Bus line (low)
5	SHIELD	

(C3) (C4) EH fieldbus execution, connector - M12 - 4 pin (2)		
PIN	SIGNAL	TECHNICAL SPECIFICATION (1)
1	TX+	Transmitter
2	RX+	Receiver
3	TX-	Transmitter
4	RX-	Receiver
Housing	SHIELD	

(1) Shield connection on connector's housing is recommended

(2) Only for AES execution

16.4 Remote pressure transducer connector - M12 - 5 pin - only for /W option - for AEB and AES (D)

PIN	SIGNAL	TECHNICAL SPECIFICATION	Voltage	Current
1	VF +24V	Power supply +24Vdc	Connect	Connect
2	TR	Signal transducer maximum range ± 10 Vdc / ± 20 mA, software selectable Defaults are $0 \div 10$ Vdc for standard and $4 \div 20$ mA for /C option	Connect	Connect
3	AGND	Common GND for transducer power and signals	Connect	/
4	NC	Not Connect	/	/
5	NC	Not Connect	/	/

Remote pressure transducer connection - example

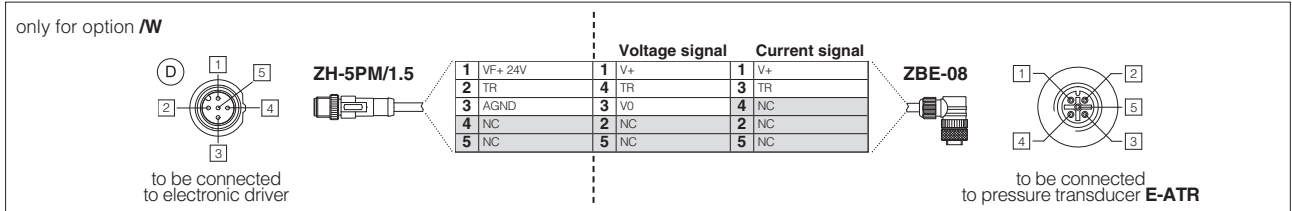

Note: connectors front view

16.5 Solenoid connection - only for A

PIN	SIGNAL	TECHNICAL SPECIFICATION	Connector code 666
1	COIL	Power supply	
2	COIL	Power supply	
3	GND	Ground	

16.6 AEB connections layout

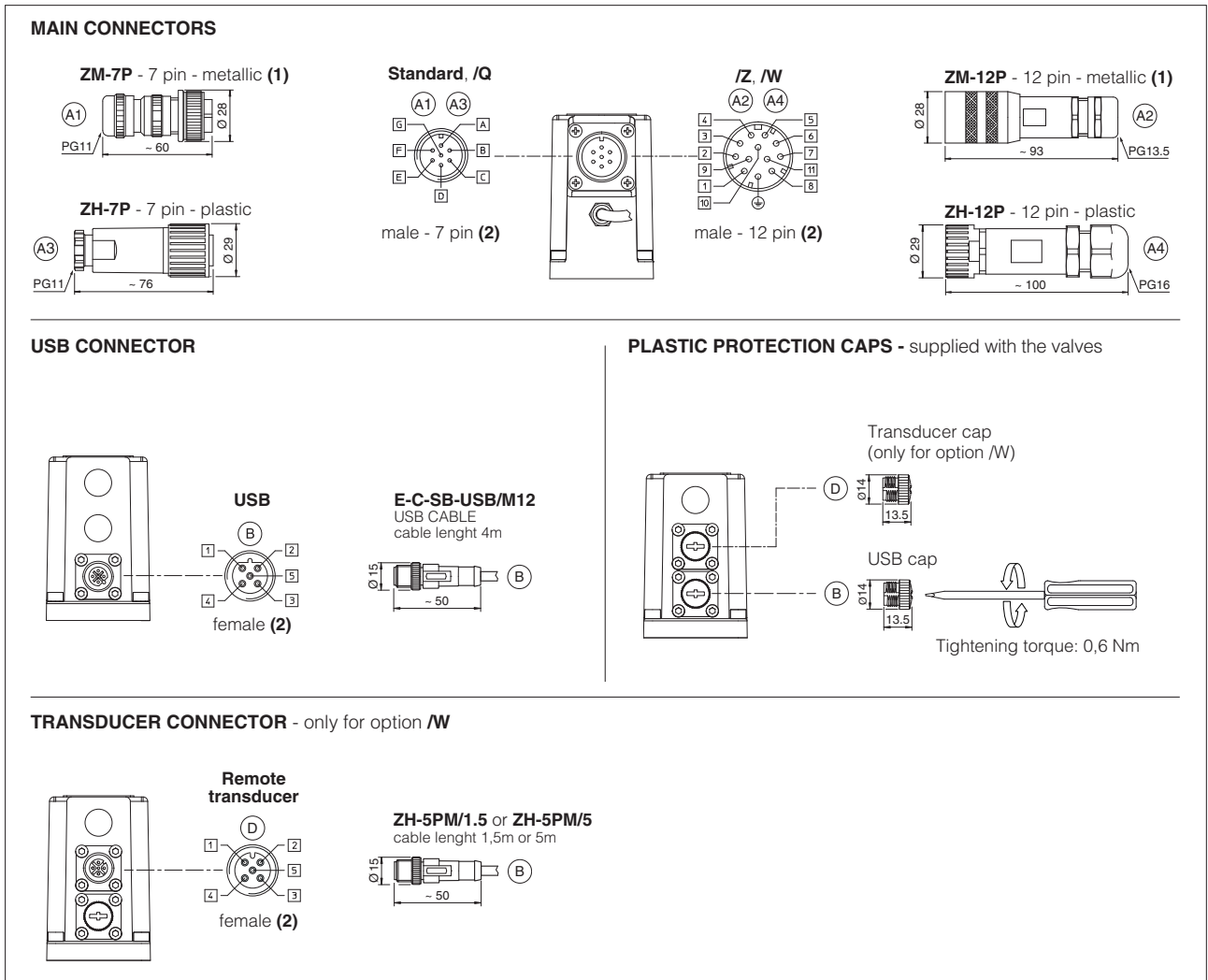

(1) Use of metallic connectors is strongly recommended in order to fulfill EMC requirements

(2) Pin layout always referred to driver's view

16.7 AES connections layout

MAIN CONNECTORS

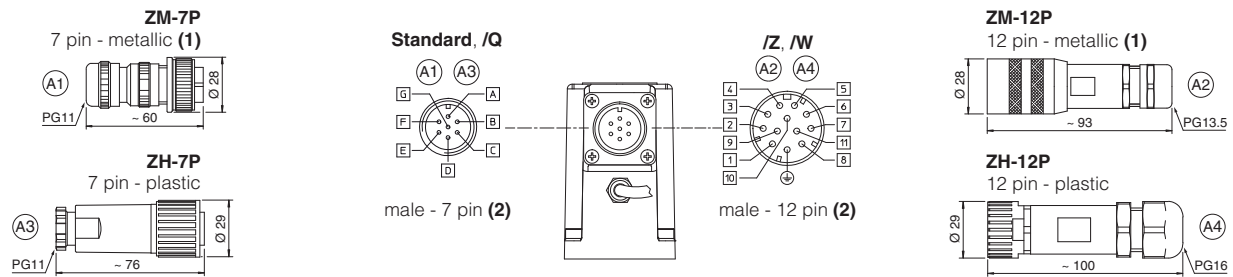

FIELDBUS CONNECTORS

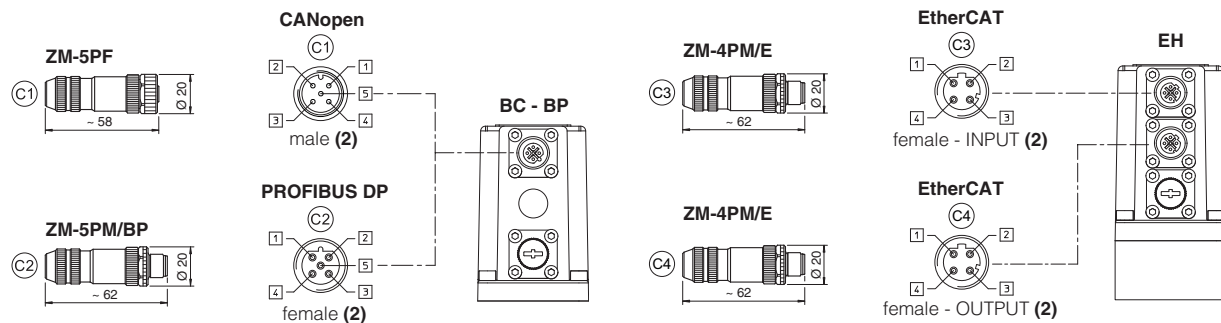

USB CONNECTOR

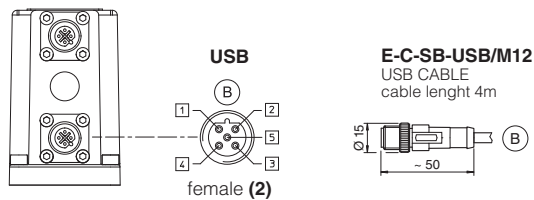

PLASTIC PROTECTION CAPS - supplied with the valves

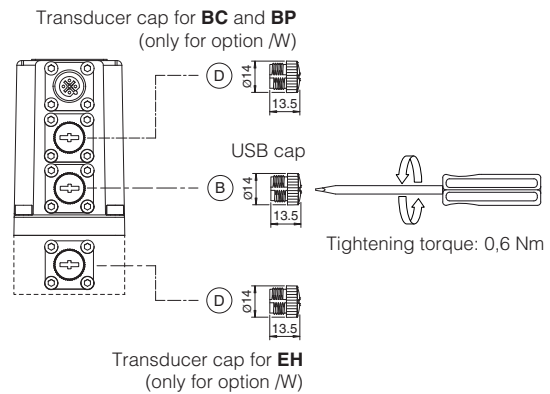

TRANSDUCER CONNECTOR - only for option /W

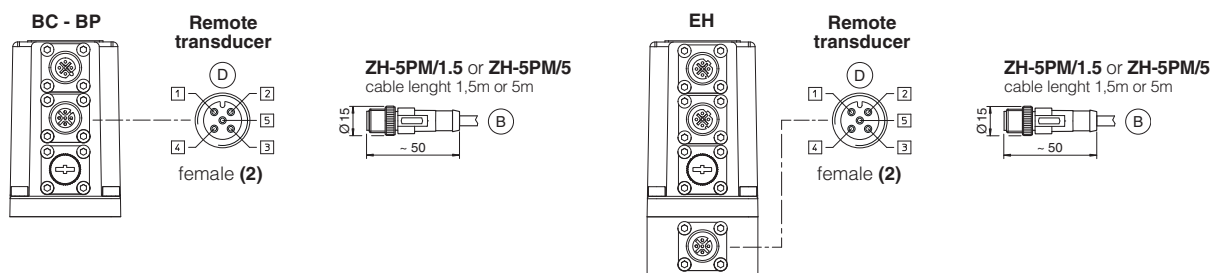

(1) Use of metallic connectors is strongly recommended in order to fulfill EMC requirements

(2) Pin layout always referred to driver's view

17 CONNECTORS CHARACTERISTICS - to be ordered separately

17.1 Main connectors - 7 pin - for AEB and AES

CONNECTOR TYPE	POWER SUPPLY	POWER SUPPLY
CODE	(A1) ZM-7P	(A3) ZH-7P
Type	7pin female straight circular	7pin female straight circular
Standard	According to MIL-C-5015	According to MIL-C-5015
Material	Metallic	Plastic reinforced with fiber glass
Cable gland	PG11	PG11
Recommended cable	LiYCY 7 x 0,75 mm ² max 20 m (logic and power supply) or LiYCY 7 x 1 mm ² max 40 m (logic and power supply)	LiYCY 7 x 0,75 mm ² max 20 m (logic and power supply) or LiYCY 7 x 1 mm ² max 40 m (logic and power supply)
Conductor size	up to 1 mm ² - available for 7 wires	up to 1 mm ² - available for 7 wires
Connection type	to solder	to solder
Protection (EN 60529)	IP 67	IP 67

17.2 Main connectors - 12 pin - for AEB and AES

CONNECTOR TYPE	POWER SUPPLY	POWER SUPPLY
CODE	(A2) ZM-12P	(A4) ZH-12P
Type	12pin female straight circular	12pin female straight circular
Standard	DIN 43651	DIN 43651
Material	Metallic	Plastic reinforced with fiber glass
Cable gland	PG13,5	PG16
Recommended cable	LiYCY 12 x 0,75 mm ² max 20 m (logic and power supply)	LiYCY 10 x 0,14mm ² max 40 m (logic) LiYY 3 x 1mm ² max 40 m (power supply)
Conductor size	0,5 mm ² to 1,5 mm ² - available for 12 wires	0,14 mm ² to 0,5 mm ² - available for 9 wires 0,5 mm ² to 1,5 mm ² - available for 3 wires
Connection type	to crimp	to crimp
Protection (EN 60529)	IP 67	IP 67

17.3 Fieldbus communication connectors - only for AES

CONNECTOR TYPE	BC CANopen (1)		BP PROFIBUS DP (1)		EH EtherCAT (2)	
CODE	(C1) ZM-5PF	(C2) ZM-5PM	(C1) ZM-5PF/BP	(C2) ZM-5PM/BP	(C1) (C2) ZM-4PM/E	
Type	5 pin female straight circular	5 pin male straight circular	5 pin female straight circular	5 pin male straight circular	4 pin male straight circular	
Standard	M12 coding A – IEC 61076-2-101		M12 coding B – IEC 61076-2-101		M12 coding D – IEC 61076-2-101	
Material	Metallic		Metallic		Metallic	
Cable gland	Pressure nut - cable diameter 6÷8 mm		Pressure nut - cable diameter 6÷8 mm		Pressure nut - cable diameter 4÷8 mm	
Cable	CANbus Standard (DR 303-1)		PROFIBUS DP Standard		Ethernet standard CAT-5	
Connection type	screw terminal		screw terminal		terminal block	
Protection (EN 60529)	IP67		IP 67		IP 67	

(1) E-TRM-** terminators can be ordered separately - see tech table **GS500**

(2) Internally terminated

17.4 Pressure transducer connectors - only for /W option

CONNECTOR TYPE	TRANSDUCER	
CODE	(D1) ZH-5PM/1.5	(D1) ZH-5PM/5
Type	5 pin male straight circular	
Standard	M12 coding A – IEC 61076-2-101	
Material	Plastic	
Cable gland	Connector moulded on cables 1,5 m lenght 5 m lenght	
Cable	5 x 0,25 mm ²	
Connection type	molded cable	
Protection (EN 60529)	IP 67	

18 PLUGS LOCATION FOR PILOT/DRAIN CHANNELS

Depending on the position of internal plugs, different pilot/drain configurations can be obtained as shown below.
 To modify the pilot/drain configuration, proper plugs must only be interchanged. The plugs have to be sealed using loctite 270.
 Standard valves configuration provides internal pilot and external drain

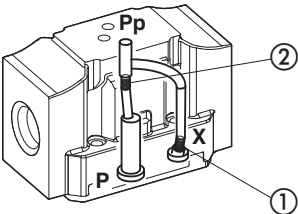
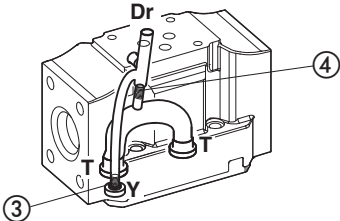
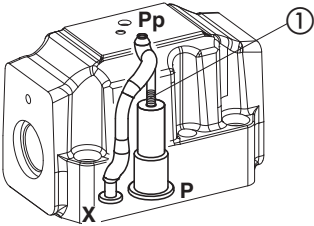
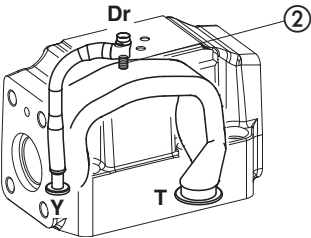
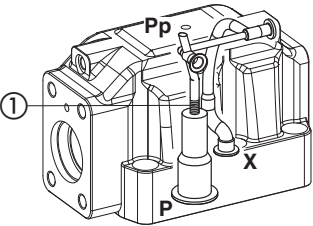
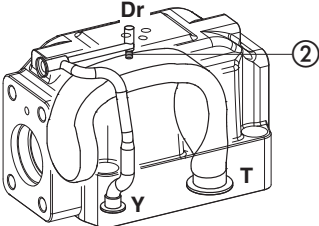
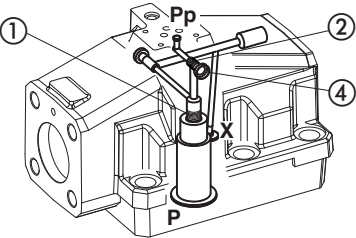
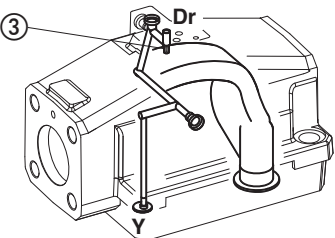
<p>DPZO-1 Pilot channels</p> 	<p>Drain channels</p> 	<p>Internal piloting: blinded plug SP-X300F ① in X; External piloting: blinded plug SP-X300F ② in Pp; Internal drain: blinded plug SP-X300F ③ in Y; External drain: blinded plug SP-X300F ④ in Dr.</p>
<p>DPZO-2 Pilot channels</p> 	<p>Drain channels</p> 	<p>Internal piloting: Without blinded plug SP-X300F ①; External piloting: Add blinded plug SP-X300F ①; Internal drain: Without blinded plug SP-X300F ②; External drain: Add blinded plug SP-X300F ②.</p>
<p>DPZO-4 Pilot channels</p> 	<p>Drain channels</p> 	<p>Internal piloting: Without blinded plug SP-X500F ①; External piloting: Add blinded plug SP-X500F ①; Internal drain: Without blinded plug SP-X300F ②; External drain: Add blinded plug SP-X300F ②.</p>
<p>DPZO-6 Pilot channels</p> 	<p>Drain channels</p> 	<p>Internal piloting: Without plug ①; External piloting: Add DIN-908 M16x1,5 in pos ①; Add plug SP-X325A in pos ②; Internal drain: Without blinded plug SP-X300F ③; External drain: Add blinded plug SP-X300F ③.</p> <p>To reach the orifice ② remove plug ④ = G1/8"</p>

19 FASTENING BOLTS AND SEALS

Type	Size	Fastening bolts	Seals
DPZO	1 = 10	4 socket head screws M6x40 class 12.9 Tightening torque = 15 Nm	5 OR 2050; Diameter of ports A, B, P, T: Ø 11 mm (max) 2 OR 108 Diameter of ports X, Y: Ø = 5 mm (max)
	2 = 16	4 socket head screws M10x50 class 12.9 Tightening torque = 70 Nm 2 socket head screws M6x45 class 12.9 Tightening torque = 15 Nm	4 OR 130; Diameter of ports A, B, P, T: Ø 20 mm (max) 2 OR 2043 Diameter of ports X, Y: Ø = 7 mm (max)
	4 = 25	6 socket head screws M12x60 class 12.9 Tightening torque = 125 Nm	4 OR 4112; Diameter of ports A, B, P, T: Ø 24 mm (max) 2 OR 3056 Diameter of ports X, Y: Ø = 7 mm (max)
	6 = 32	6 socket head screws M20x90 class 12.9 Tightening torque = 600 Nm	4 OR 144; Diameter of ports A, B, P, T: Ø 34 mm (max) 2 OR 3056 Diameter of ports X, Y: Ø = 7 mm (max)

20 INSTALLATION DIMENSIONS FOR DPZO-1 [mm]

ISO 4401: 2005
 Mounting surface: 4401-05-05-0-05 (see table P005)

	Mass [kg]		
	A	AEB, AES	AES-EH
DPZO-*-15	7,7	8,1	8,2
DPZO-*-17	8,6	9	9,1
Option /G	+0,9		

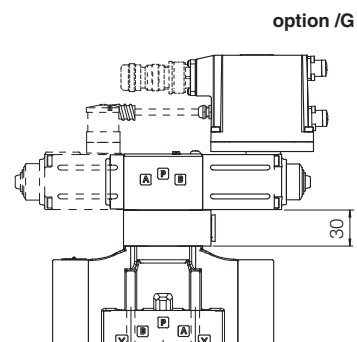
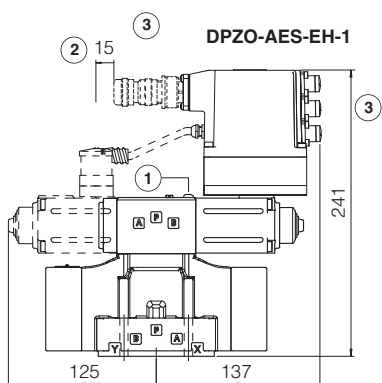
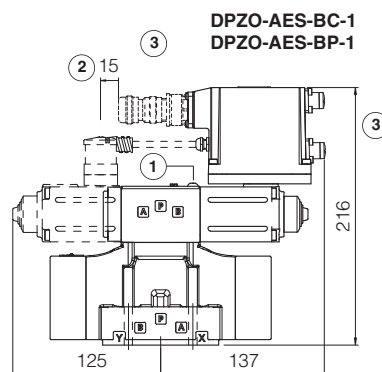
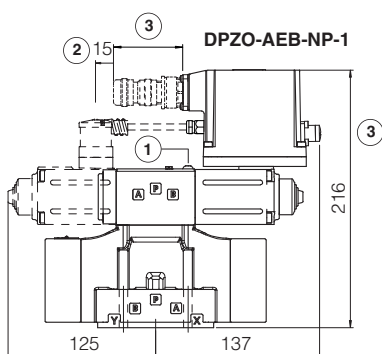
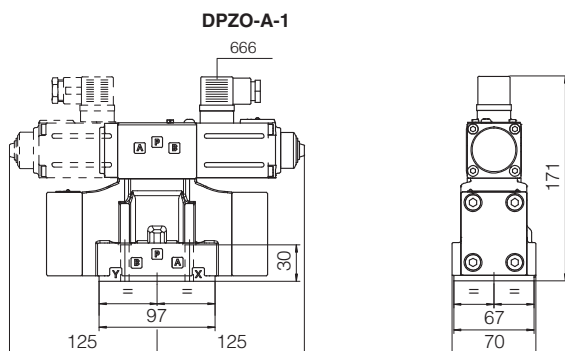

Dotted line = double solenoid version

- ① = Air bleeding 3
- ② = Space to remove the connectors
- ③ = The dimensions of all connectors must be considered, see section 16.6 and 16.7

Note: for option /B the solenoid and the on-board digital driver are at side of port B of the main stage

21 INSTALLATION DIMENSIONS FOR DPZO-2 [mm]

ISO 4401: 2005

Mounting surface: 4401-07-07-0-05 (see table P005)

	Mass [kg]		
	A	AEB, AES	AES-EH
DPZO-*-25	11,9	12,3	12,4
DPZO-*-27	12,8	13,2	13,3
Option /G	+0,9		

DPZO-A-2

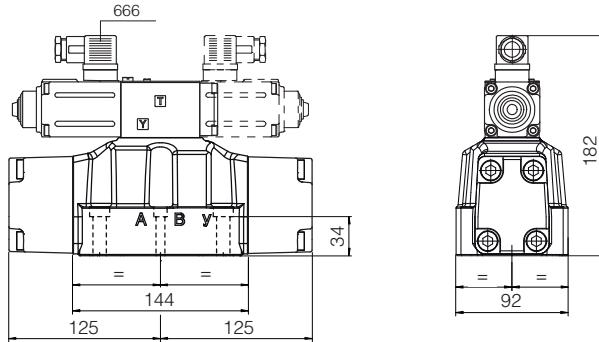

DPZO-AEB-NP-2

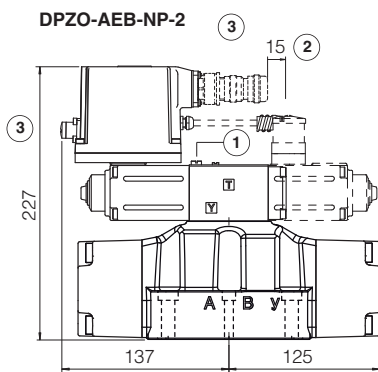

DPZO-AES-BC-2
DPZO-AES-BP-2

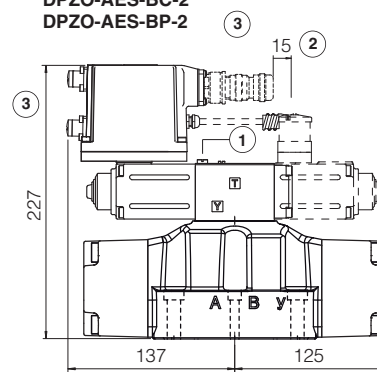

DPZO-AES-EH-2

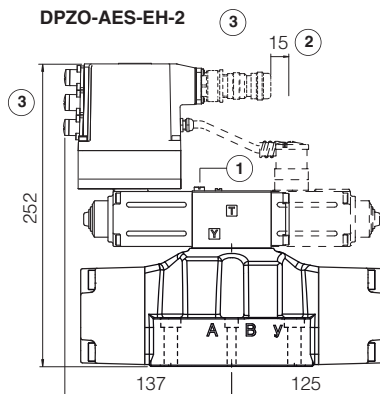

option /G

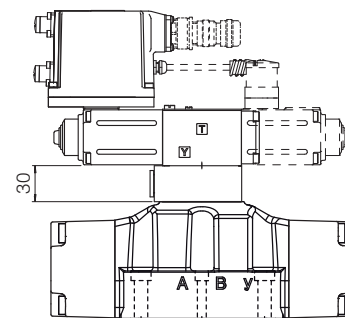

Dotted line = double solenoid version

① = Air bleeding 

② = Space to remove the connectors

③ = The dimensions of all connectors must be considered, see section 16.6 and 16.7

Note: for option /B the solenoid and the on-board digital driver are at side of port B of the main stage

22 INSTALLATION DIMENSIONS FOR DPZO-4 [mm]

ISO 4401: 2005

Mounting surface: 4401-08-08-0-05 (see table P005)

	Mass [kg]		
	A	AEB, AES	AES-EH
DPZO-*-45	17,1	18	18,1
DPZO-*-47	18	18,9	19
Option /G		+0,9	

DPZO-A-4

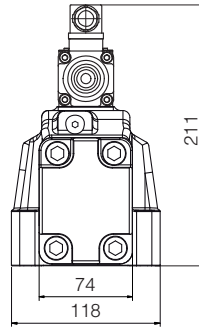
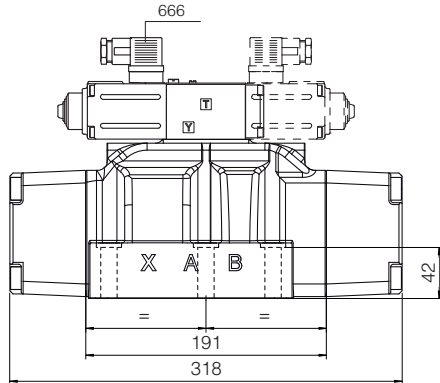

DPZO-AEB-NP-4

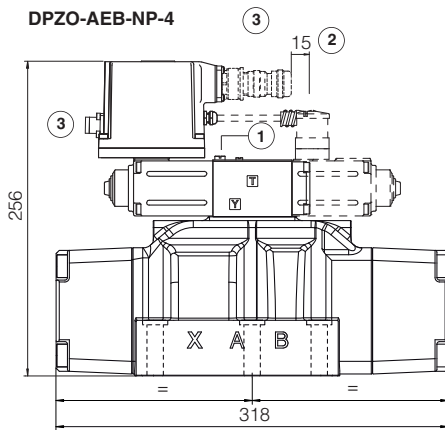

DPZO-AES-BC-4
DPZO-AES-BP-4

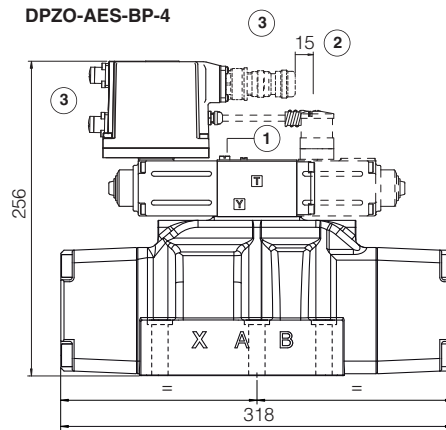

DPZO-AES-EH-4

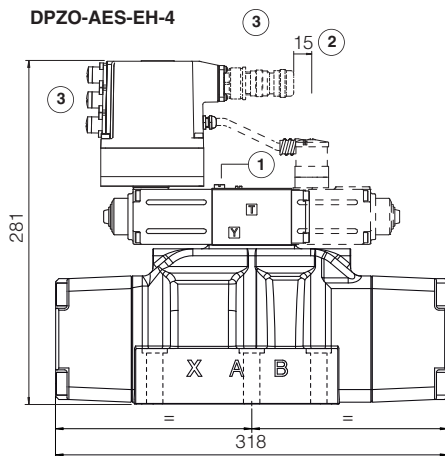

option /G

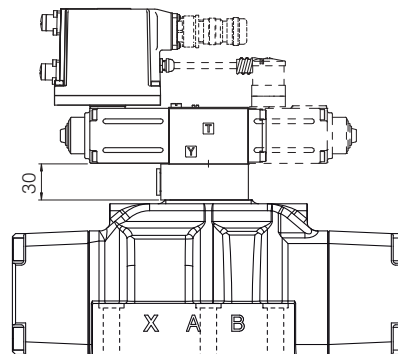

Dotted line = double solenoid version

① = Air bleeding 

② = Space to remove the connectors

③ = The dimensions of all connectors must be considered, see section 16.6 and 16.7

Note: for option /B the solenoid and the on-board digital driver are at side of port B of the main stage

23 INSTALLATION DIMENSIONS FOR DPZO-6 [mm]

ISO 4401: 2005

Mounting surface: 4401-10-09-0-05 (see table P005)

	Mass [kg]		
	A	AEB, AES	AES-EH
DPZO-*65	42,1	42,5	42,6
DPZO-*67	42,7	43,1	43,2
Option /G	+2,3		

DPZO-A-6

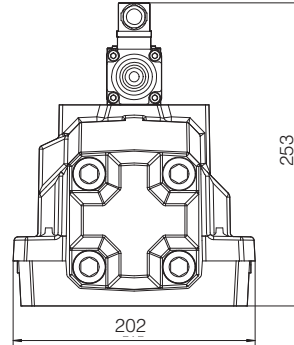
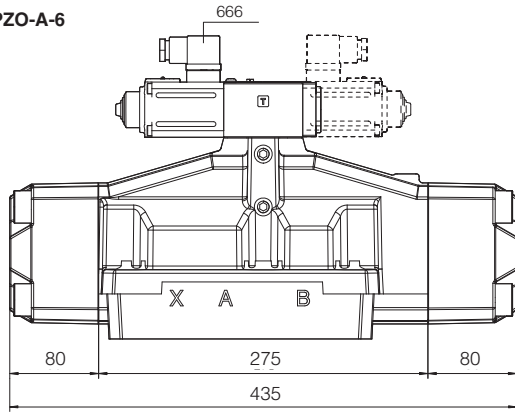

DPZO-AEB-NP-6

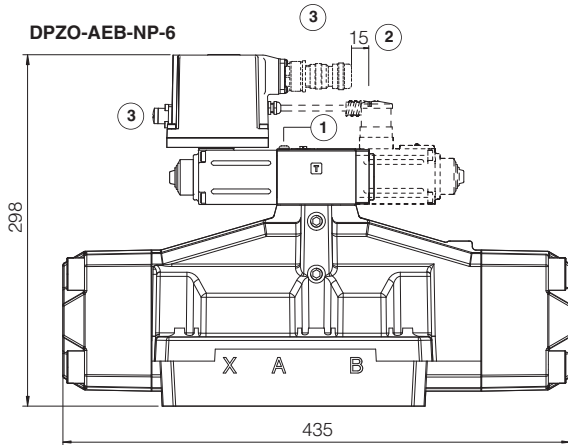

DPZO-AES-BC-6
DPZO-AES-BP-6

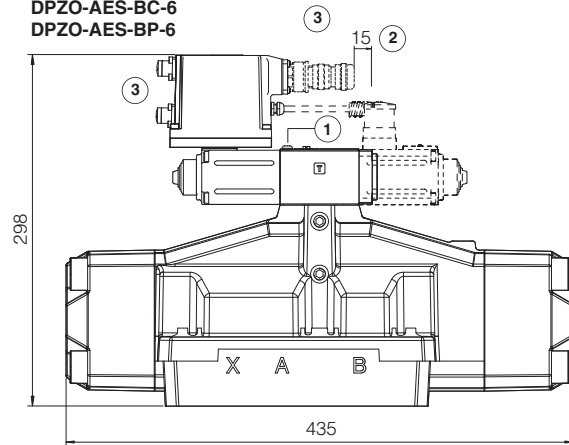

DPZO-AES-EH-6

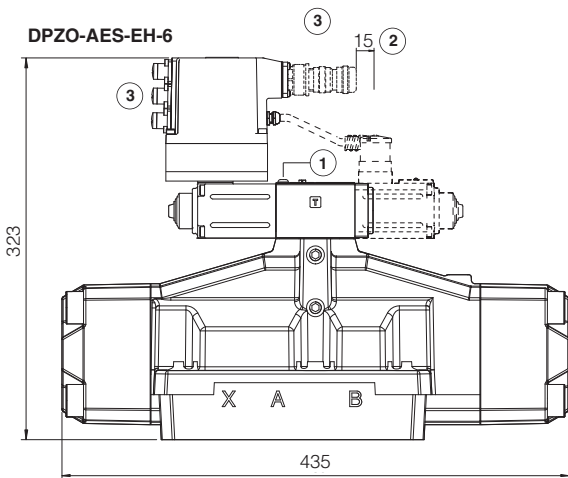

option /G

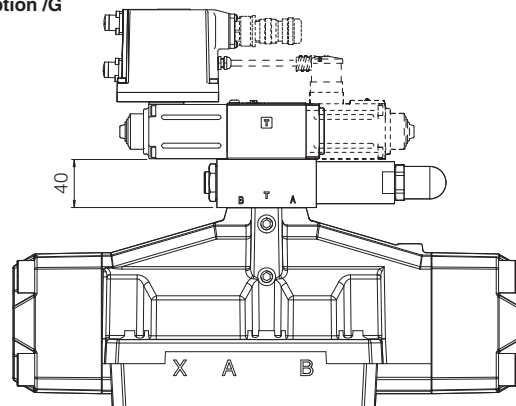

Dotted line = double solenoid version

① = Air bleeding 

② = Space to remove the connectors

③ = The dimensions of all connectors must be considered, see section 16.6 and 16.7

Note: for option /B the solenoid and the on-board digital driver are at side of port B of the main stage

24 RELATED DOCUMENTATION

FS001	Basics for digital electrohydraulics	GS510	Fieldbus
FS900	Operating and maintenance information for proportional valves	K800	Electric and electronic connectors
G010	E-MI-AC analog driver	P005	Mounting surfaces for electrohydraulic valves
G020	E-MI-AS-IR digital driver	QB120	Quickstart for AEB valves commissioning
G030	E-BM-AS digital driver	QF120	Quickstart for AES valves commissioning
GS050	E-BM-AES digital driver		
GS500	Programming tools		