

Link do produktu: <https://www.hektos.eu/flansza-afs-106-g-sae-3000-psi-p-1620.html>

Flansza AFS 106 G SAE 3000 PSI

Cena brutto	187,00 zł
Cena netto	152,03 zł
Dostępność	Dostępny
Numer katalogowy	AFS106G
Marka	Rolltorq

Opis produktu

Flansza SAE 1" 1/2 SAE 3000 PSI z gwintem BSP, oringiem

Oddzielnie oferujemy zestawy śrub - prosimy o podanie wielkości śrub lub pełnego kodu pompy przy zamówieniu lub o kontakt z nami:

+48 22 203 5079

shop@hektos.eu

Tabela wymiarów flanz wysokociśnieniowych AFS G 3000 PSI

Typ konstrukcji:	kołnierz wkręcany SAE
Kształt:	prosty
Norma:	SAE J 518 C ISO 6162
Zamocowanie:	otwór pod śrubę
Szereg ciśnieniowy:	3000 PSI
Materiał:	S355J2G3
Ochrona powierzchni:	olejowana

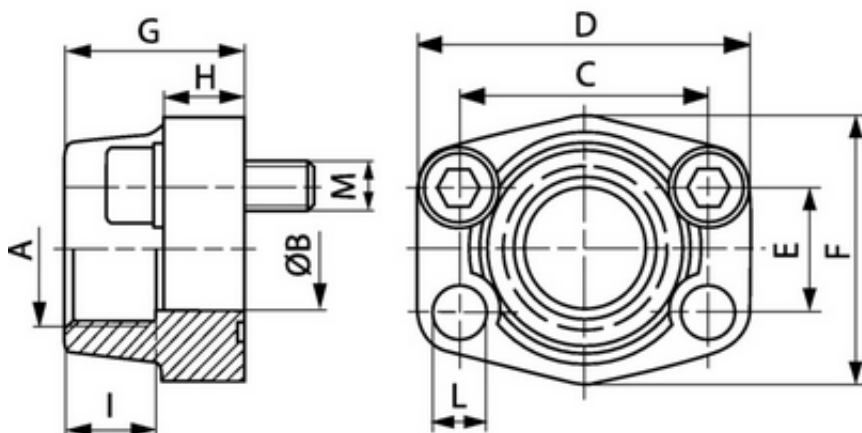

Oznaczenie	Rozmiar wg typoszeregu	A	ØB	C	D	E	F	G	H
	u								

AFS 80 G3/8	1/2"	G3/8"-19	13	38,1	54	17,5	46	36	16
AFS 80 G1/2	1/2"	G1/2"-14	13	38,1	54	17,5	46	36	16
AFS 100 G1/2	3/4"	G1/2"-14	13	47,6	65	22,2	50	36	18
AFS 100 G3/4	3/4"	G3/4"-14	19	47,6	65	22,2	50	36	18
AFS 102 G1/2	1"	G1/2"-14	13	52,4	70	26,2	55	38	18
AFS 102 G3/4	1"	G3/4"-14	19	52,4	70	26,2	55	35	21
AFS 102 G1	1"	G1"-11	25	52,4	70	26,2	55	38	18
AFS 104 G3/4	1"1/4	G3/4"-14	19	58,7	79	30,2	68	41	21
AFS 104 G1 M10	1"1/4	G1"-11	25	58,7	81	30,2	65	42	25
AFS 104 G1 M12	1"1/4	G1"1-11	25	58,7	81	30,2	65	42	25
AFS 104 G114 M10	1"1/4	G1"1/4-11	32	58,7	79	30,2	68	41	21
AFS 104 G114 M12	1"1/4	G1"1/4-11	32	58,7	79	30,2	68	41	21
AFS 106 G3/4	1"1/2	G3/4"-14	19	69,9	93	35,7	78	45	25
AFS 106 G1	1"1/2	G1"-11	25	69,9	93	35,7	78	45	25
AFS 106 G11/4	1"1/2	G1"1/4-11	32	69,9	95	35,7	78	45	27
AFS 106 G11/2	1"1/2	G1"1/2-11	38	69,9	93	35,7	78	45	25
AFS 108 G1	2"	G1"-11	25	77,8	102	42,9	90	45	25
AFS 108 G11/4	2"	G1"1/4-11	32	77,8	102	42,9	90	45	25
AFS 108 G11/2	2"	G1"1/2-11	38	77,8	102	42,9	90	45	25
AFS 108 G2	2"	G2"-11	51	77,8	102	42,9	90	45	25
AFS 110 G11/2	2"1/2	G1"1/2-11	38	88,9	114	50,8	105	50	25
AFS 110 G2	2"1/2	G2"-11	51	88,9	114	50,8	105	50	25
AFS 110 G21/2	2"1/2	G2"1/2-11	63	88,9	114	50,8	105	50	25
AFS 112 G21/2	3"	G2"1/2-11	63	106,4	134	61,9	124	50	27
AFS 112 G3	3"	G3"-11	73	106,4	134	61,9	124	50	27
AFS 114 G3	3"1/2	G3"-11	73	120,7	152	69,9	136	48	27
AFS 114 G31/2	3"1/2	G3"1/2-11	89	120,7	152	69,9	136	48	27

AFS 116 G31/2	4"	G3"1/2-11	89	130,2	162	77,8	146	48	27
AFS 116 G4	4"	G4"-11	99	130,2	162	77,8	146	48	27

Sprawdź wymiary

Tabela wymiarów flansz wysokociśnieniowych AFS G 3000 PSI

Typ konstrukcji:	kołnierz wkręcany SAE
Kształt:	prosty
Norma:	SAE J 518 C ISO 6162
Zamocowanie:	otwór pod śrubę
Szereg ciśnieniowy:	3000 PSI
Materiał:	S355J2G3
Ochrona powierzchni:	olejowana

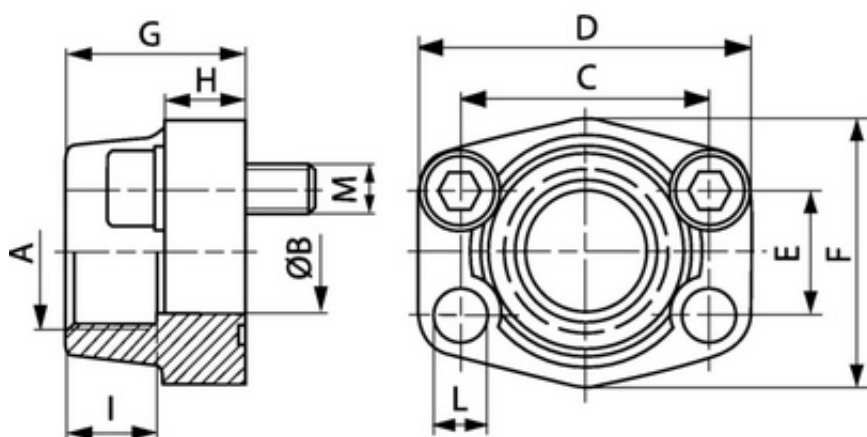

Oznaczenie	Rozmiar wg typoszeregu	A	ØB	C	D	E	F	G	H
AFS 80 G3/8	1/2"	G3/8"-19	13	38,1	54	17,5	46	36	16
AFS 80 G1/2	1/2"	G1/2"-14	13	38,1	54	17,5	46	36	16
AFS 100 G1/2	3/4"	G1/2"-14	13	47,6	65	22,2	50	36	18
AFS 100 G3/4	3/4"	G3/4"-14	19	47,6	65	22,2	50	36	18
AFS 102 G1/2	1"	G1/2"-14	13	52,4	70	26,2	55	38	18
AFS 102 G3/4	1"	G3/4"-14	19	52,4	70	26,2	55	35	21
AFS 102 G1	1"	G1"-11	25	52,4	70	26,2	55	38	18

AFS 104 G3/4	1"1/4	G3/4"-14	19	58,7	79	30,2	68	41	21
AFS 104 G1 M10	1"1/4	G1"-11	25	58,7	81	30,2	65	42	25
AFS 104 G1 M12	1"1/4	G1"1-11	25	58,7	81	30,2	65	42	25
AFS 104 G114 M10	1"1/4	G1"1/4-11	32	58,7	79	30,2	68	41	21
AFS 104 G114 M12	1"1/4	G1"1/4-11	32	58,7	79	30,2	68	41	21
AFS 106 G3/4	1"1/2	G3/4"-14	19	69,9	93	35,7	78	45	25
AFS 106 G1	1"1/2	G1"-11	25	69,9	93	35,7	78	45	25
AFS 106 G11/4	1"1/2	G1"1/4-11	32	69,9	95	35,7	78	45	27
AFS 106 G11/2	1"1/2	G1"1/2-11	38	69,9	93	35,7	78	45	25
AFS 108 G1	2"	G1"-11	25	77,8	102	42,9	90	45	25
AFS 108 G11/4	2"	G1"1/4-11	32	77,8	102	42,9	90	45	25
AFS 108 G11/2	2"	G1"1/2-11	38	77,8	102	42,9	90	45	25
AFS 108 G2	2"	G2"-11	51	77,8	102	42,9	90	45	25
AFS 110 G11/2	2"1/2	G1"1/2-11	38	88,9	114	50,8	105	50	25
AFS 110 G2	2"1/2	G2"-11	51	88,9	114	50,8	105	50	25
AFS 110 G21/2	2"1/2	G2"1/2-11	63	88,9	114	50,8	105	50	25
AFS 112 G21/2	3"	G2"1/2-11	63	106,4	134	61,9	124	50	27
AFS 112 G3	3"	G3"-11	73	106,4	134	61,9	124	50	27
AFS 114 G3	3"1/2	G3"-11	73	120,7	152	69,9	136	48	27
AFS 114 G31/2	3"1/2	G3"1/2-11	89	120,7	152	69,9	136	48	27
AFS 116 G31/2	4"	G3"1/2-11	89	130,2	162	77,8	146	48	27
AFS 116 G4	4"	G4"-11	99	130,2	162	77,8	146	48	27