

PA and PAC PUMPS



Single flow models : from 12 to 114 cc
Twin-flow models : from 2 x 25 to 2 x 57 cc

350 bar continuous pressure
500 bar peak pressure
Dual direction of rotation

Of unique design, the PA/PAC pumps offer a robust solution with long service life for high pressure requirements in truck hydraulics.

Relatively insensitive to contamination, these pumps are particularly well suited to the harshest environments.

The (patented) way the pumping elements are arranged means the pumps can rotate either clockwise or anti-clockwise without any user intervention.

As all LEDUC truck pumps, this range is fitted with the latest innovation in terms of sealing :

- front of pump fitted with two shaft seals :
externally, a seal capable of resisting high temperatures of the gearbox,
and internally, a seal adapted to the hydraulic requirements.

- a transparent flexible tube fitted between the two seals, to protect these seals from dirt from the road, from high pressure water jet during washing of vehicle etc.
- O ring between pump and PTO to reinforce liaison between pump and PTO (instead of paper seal).

In short, the PA/PAC pumps are :

- simple to use ;
- capable of withstanding difficult conditions :
- pressure peaks ;
- slightly degraded fluides ;
- an economic solution for twin-flow requirements.



The range



Single flow

Model	Reference	Displacement (cc)	Ports		Weight (kgs)
			inlet	output	
PA 12	0511445	12	G 1 1/2"	G 3/4"	12.5
PA 18	0511450	18	G 1 1/2"	G 3/4"	12.5
PA 25	0511510	28	G 1 1/2"	G 3/4"	15
PA 32	0511515	34	G 1 1/2"	G 3/4"	15
PA 40	0511520	43	G 1 1/2"	G 3/4"	15
PA 50	0511525	50	G 1 1/2"	G 3/4"	15
PA 63	0511530	66	G 2"	G 3/4"	23.5
PA 80	0511535	82	G 2"	G 3/4"	23.5
PA 100	0511565	104	G 2"	G 3/4"	23.5
PA 114	0511570	114	G 2"	G 3/4"	23.5
PAC 25	0511470	26	G 1 1/2"	G 3/4"	12.5
PAC 40	0511460	40	G 1 1/2"	G 3/4"	12.5
PAC 50	0511465	50	G 1 1/2"	G 3/4"	12.5
PAC 65	0511490	65	G 1 1/2"	G 3/4"	16
PAC 80	0511705	78	G 1 1/2"	G 3/4"	17

Twin-flow

Model	Reference	Displacement (cc)	Ports		Weight (kgs)
			inlet	output	
PA2 32	0511545	2-x-32	G 2"	G 3/4"	23.5
PA2 40	0511550	2-x-39	G 2"	G 3/4"	23.5
PA2 50	0511555	2-x-52	G 2"	G 3/4"	23.5
PA2 57	0511560	2-x-57	G 2"	G 3/4"	23.5
PAC2 25	0511480	2-x-25	G 1 1/2"	G 3/4"	16
PAC2 32	0511485	2-x-32	G 1 1/2"	G 3/4"	16
PAC2 40	0511710	2-x-39	G 1 1/2"	G 3/4"	17



Environment, see page 14

Volumetric efficiency

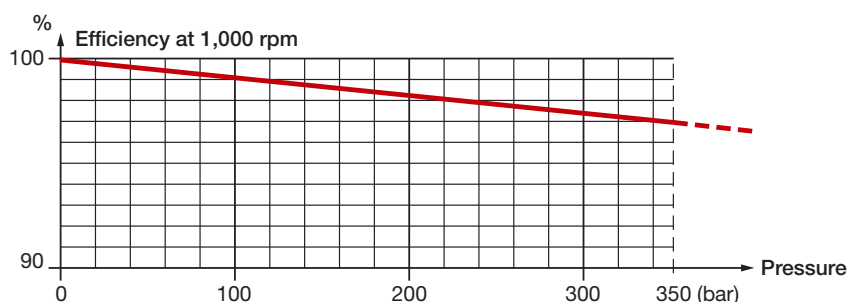

These graphs are the results of testwork done in the HL R&D laboratory, on a specific test bench, with an ISO 46 fluid at 25°C (100 cSt), the pump is fitted with an HL inlet fitting, hosing is 4 metres long, and tank situated slightly above pump.

PA and PAC PUMPS

Dimensions

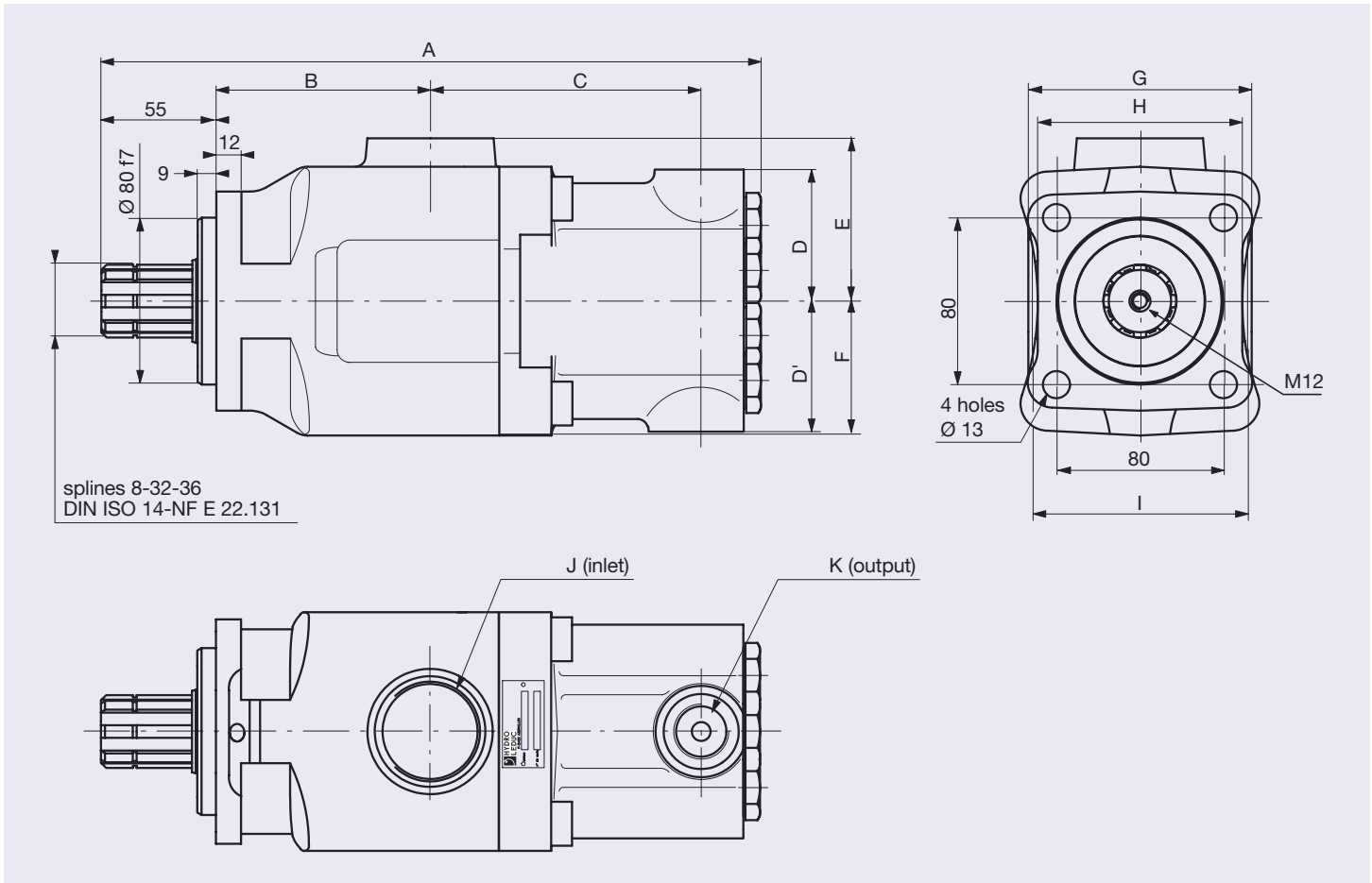

10

Model	A	B	C	D and D'	E	F	G	H	I	J inlet	K output
PA 12	281	94.9	103.3	62	73.2	54	98	-	-	G 1 ^{1/2} "	G 3/4"
PA 18	281	94.9	103.3	62	73.2	54	98	-	-	G 1 ^{1/2} "	G 3/4"
PA 25	315	102	126	47	78	65	107	98	-	G 1 ^{1/2} "	G 3/4"
PA 32	315	102	126	47	78	65	107	98	-	G 1 ^{1/2} "	G 3/4"
PA 40	315	102	126	47	78	65	107	98	-	G 1 ^{1/2} "	G 3/4"
PA 50	315	102	126	47	78	65	107	98	-	G 1 ^{1/2} "	G 3/4"
PA 63	345	123	138	69	90	68.5	124	112	120	G 2"	G 3/4"
PA 80	345	123	138	69	90	68.5	124	112	120	G 2"	G 3/4"
PA 100	345	123	138	69	90	68.5	124	112	120	G 2"	G 3/4"
PA 114	345	123	138	69	90	68.5	124	112	120	G 2"	G 3/4"
PAC 25	281	94.9	103.3	62	73.2	54	98	-	-	G 1 ^{1/2} "	G 3/4"
PAC 40	281	94.9	103.3	62	73.2	54	98	-	-	G 1 ^{1/2} "	G 3/4"
PAC 50	281	94.9	103.3	62	73.2	54	98	-	-	G 1 ^{1/2} "	G 3/4"
PAC 65	299	102.5	112.8	63	78	65	107	98	105	G 1 ^{1/2} "	G 3/4"
PAC 80	302.5	102.5	116.3	63	78	65	107	98	105	G 1 ^{1/2} "	G 3/4"
PA2 32	345	123	138	69	90	69	124	112	120	G 2"	G 3/4"
PA2 40	345	123	138	69	90	69	124	112	120	G 2"	G 3/4"
PA2 50	345	123	138	69	90	69	124	112	120	G 2"	G 3/4"
PA2 57	345	123	138	69	90	69	124	112	120	G 2"	G 3/4"
PAC2 25	299	102.5	112.8	63	78	65	107	98	105	G 1 ^{1/2} "	G 3/4"
PAC2 32	299	102.5	112.8	63	78	65	107	98	105	G 1 ^{1/2} "	G 3/4"
PAC2 40	302.5	102.5	116.3	63	78	65	107	98	105	G 1 ^{1/2} "	G 3/4"

Performance



Absorbed torque during operation

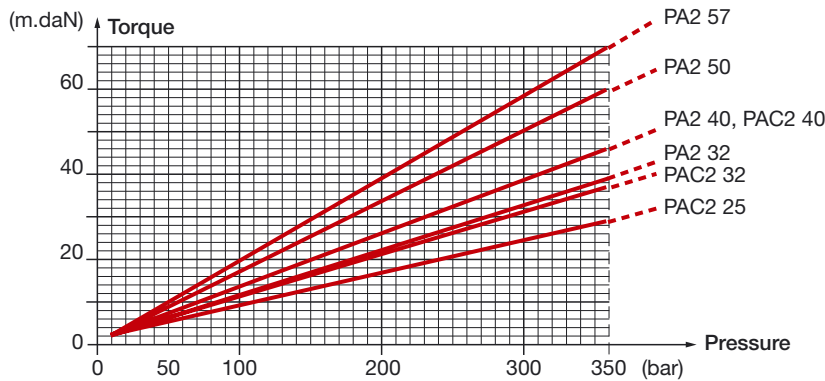
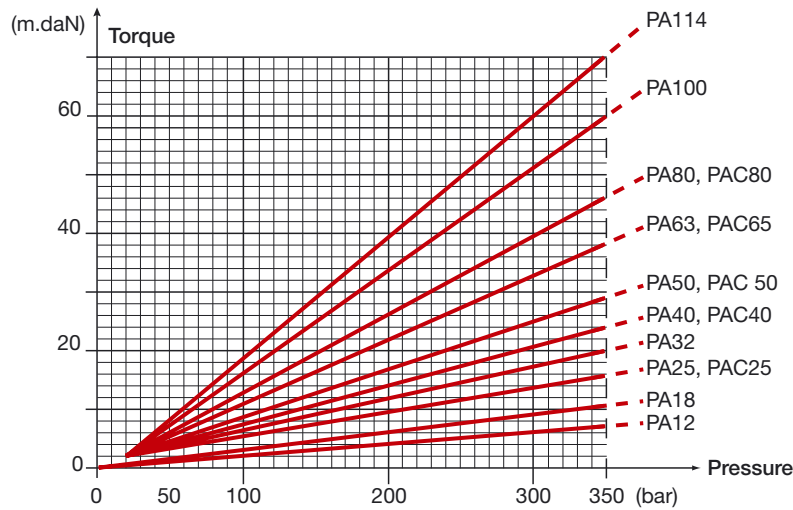

Calculating power as a function of torque

$$C = \frac{\mathcal{P}(\text{kW})}{\omega} \times 100 = \text{m.daN}$$

$$\omega = \frac{\pi N}{30}$$

$$\mathcal{P}(\text{kW}) = \frac{\Delta P \times Q}{600}$$

where :

\mathcal{P} = theoretical hydraulic power

C = torque

N = rotating speed in rpm

P = service pressure in bar

Q = flow in l/min

11

Flow

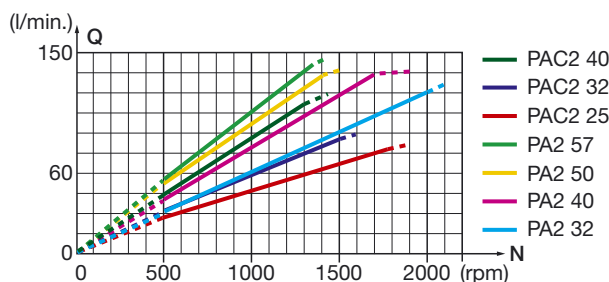
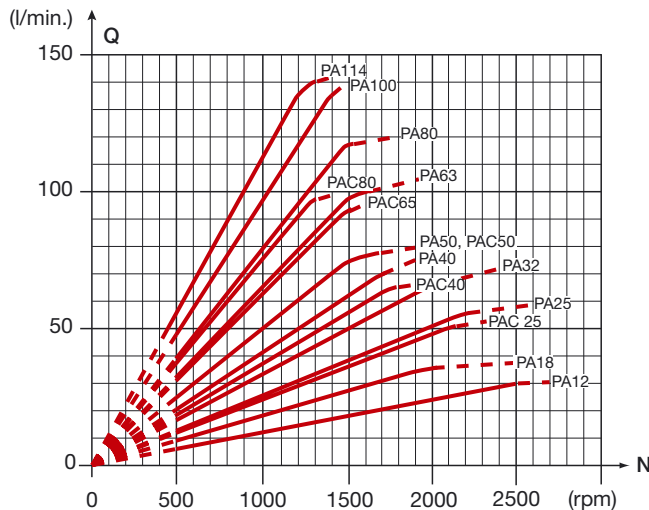

Environment, see page 14

These graphs are the results of testwork done in the HL R&D laboratory, on a specific test bench, with an ISO 46 fluid at 25°C (100 cSt), the pump is fitted with an HL inlet fitting, hosing is 4 metres long, and tank situated slightly above pump.

