

# INDUSTRIAL FIXED DISPLACEMENT PUMP

# HH 28

**3.3 cm<sup>3</sup>/rev (0.20 cu.in.)**  
**600 bar (8700 PSI)**  
**3000 rpm**

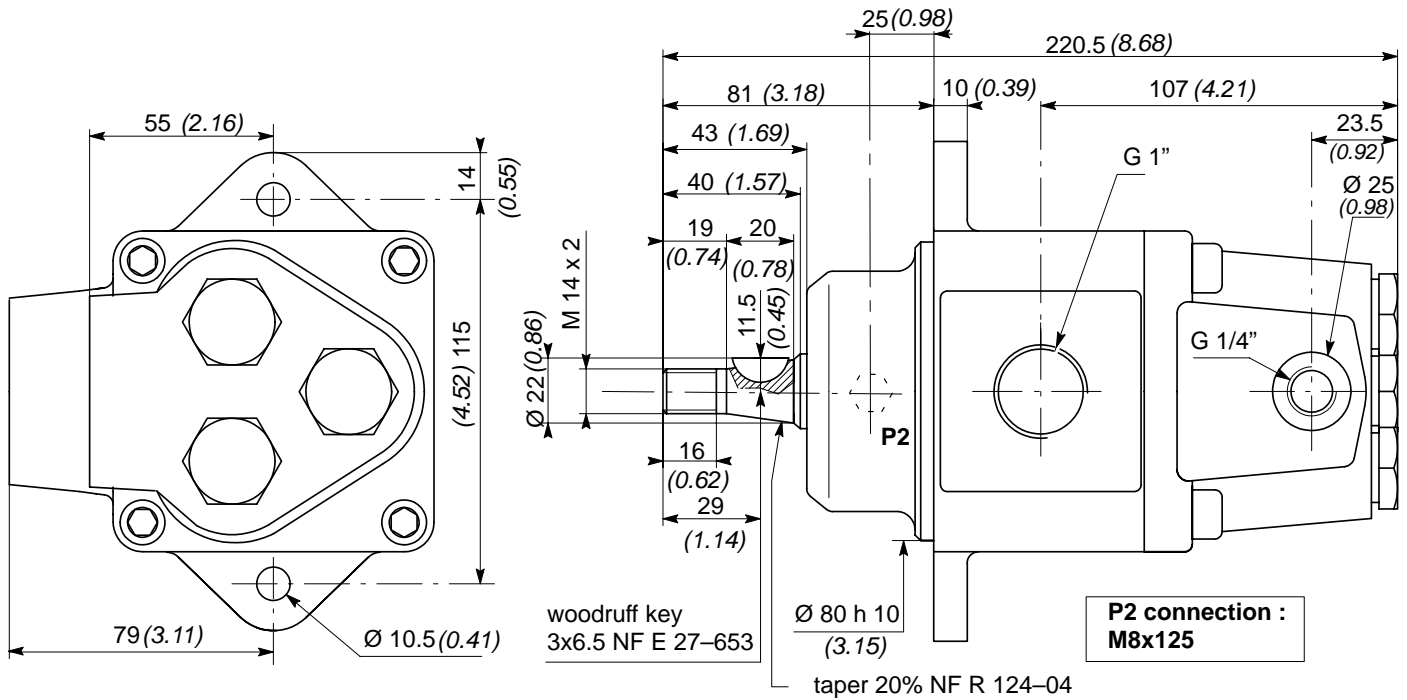

Dimensions are written in millimeters  
and (inches)

## TECHNICAL CHARACTERISTICS

Displacement	:	3,3 cm <sup>3</sup> /rev (0.20 cu.in.)
Max. continuous pressure	:	600 bar (8700 PSI)
Max. peak pressure	:	700 bar (10140 PSI)
Self-priming speed	:	3000 rpm
Peak speed	:	3500 rpm
Max. temperature	:	100-120° C (212-248° F)
Inlet Ø	:	G 1"
Outlet Ø	:	G 1/4"
Weight	:	7.6 kg (16.76 lbs)
$\frac{N_v}{p}$ mini	:	63

## PERFORMANCES

### FLOW CURVE

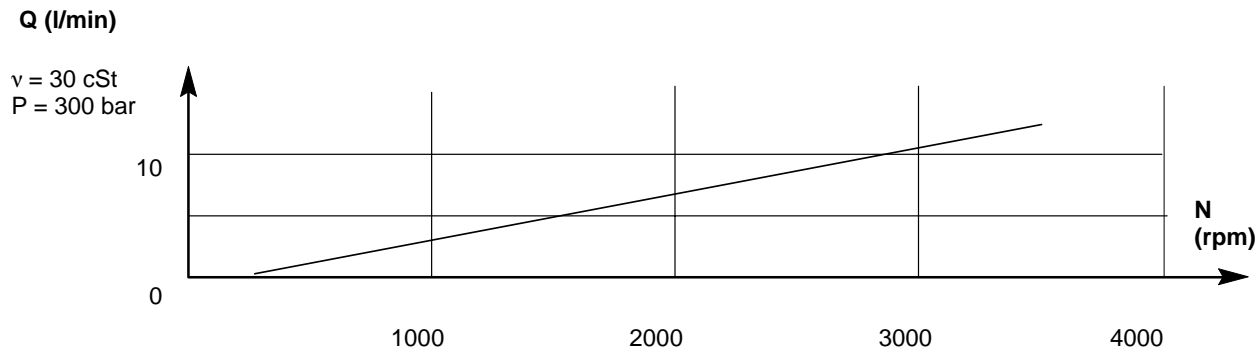

### POWER CURVE

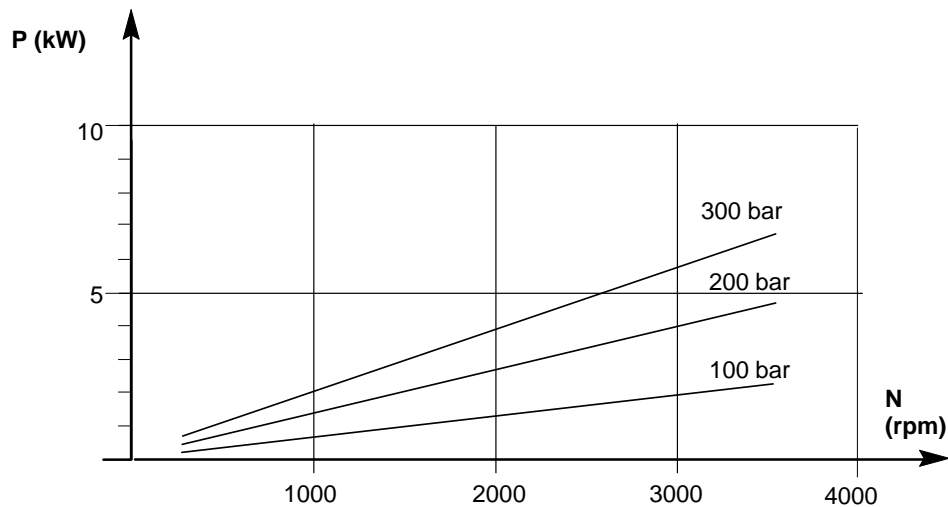

### CONDITIONS OF USE

See also sheet headed "start-up".

**FLUID :** The viscosity of the fluid at the extreme temperatures must be between 15 cSt (2.3°E) and 800 cSt (105°E). Optimum flow between 15 cSt (2.3°E) and 200 cSt (26°E).

If fluid viscosity is less than 15 cSt at extreme operating temperature please consult our Technical Department.

The standard version is equipped with AA (self-priming) valves and the P2 air bleed plug (necessary for vertical submerged position).

### CODING :

Clockwise rotation, SH : HH 28 052730